

MEDGAL VET

ORTHOPAEDIC IMPLANTS & INSTRUMENTS



VETERINARY IMPLANTS

PRODUCTS CATALOGUE

CONTENTS

▪ System 2,0	2
▪ System 2,4/2,7	9
▪ System 3,5	14
▪ Straight plates	18
▪ Compression plates	21
▪ Reconstruction plates	23
▪ Shaped plates	25
▪ Tubular plates	28
▪ TPLO plates	30
▪ Plates for double/triple pelvis osteotomy - DPO/TPO	33
▪ Pancarpal arthrodesis plate	34
▪ Pantarsal arthrodesis plate	36
▪ Condylar plate	40
▪ Instrument set for plate, screw case, plate case	43
▪ Cannulated and compression screw	46
▪ Instrument set for compression and cannulated screw	52
▪ Intramedullary nail	54
▪ Instrument set for intramedullary nail	56
▪ Spine stabilization system	58
▪ Instrument set for spine stabilization system	59
▪ External stabilization system	60
▪ TTA	61
▪ Screws and wires	65
▪ Screw selection table by patient's weight	68

First part of REF. No	Types of materials
80-X	
80-1	titanium
80-4	stainless steel

EXAMPLE

80-X-zz-zzz-zz

X = 1,4

z = number

RECONSTRUCTION LOCKING PLATE
TITANIUM | STEEL

locking screws \varnothing 2,0 mm

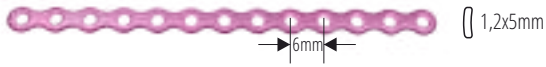

L (mm)	holes	REF No.	L (mm)	holes	REF No.
23	4	80-X-02-165-04	89	15	80-X-02-165-15
29	5	80-X-02-165-05	95	16	80-X-02-165-16
35	6	80-X-02-165-06	101	17	80-X-02-165-17
41	7	80-X-02-165-07	107	18	80-X-02-165-18
47	8	80-X-02-165-08	113	19	80-X-02-165-19
53	9	80-X-02-165-09	119	20	80-X-02-165-20
59	10	80-X-02-165-10	125	21	80-X-02-165-21
65	11	80-X-02-165-11	131	22	80-X-02-165-22
71	12	80-X-02-165-12	137	23	80-X-02-165-23
77	13	80-X-02-165-13	143	24	80-X-02-165-24
83	14	80-X-02-165-14	149	25	80-X-02-165-25

LOCKING SCREWS
self-tapping \varnothing 2,0

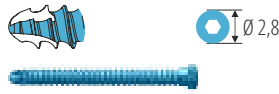

L (mm)	REF
6-40 step 2mm	80-X-01-260-L

DRILL \varnothing 1.5mm
HOLDING SLEEVE 80-4-57-122-00
SCREWDRIVER 80-4-43-33-02.1
HANDLE 80-28-5-1
SHAFT \leq 1,5 80-28-5-2

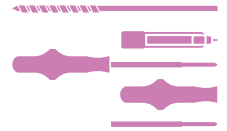

STRAIGHT PLATE
TITANIUM

cortical screws \varnothing 2,0 mm
locking screws \varnothing 2,0 mm

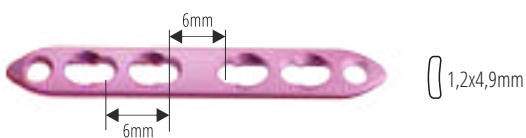

L (mm)	holes	REF No.
23	4	80-1-02-170-04
35	6	80-1-02-170-06

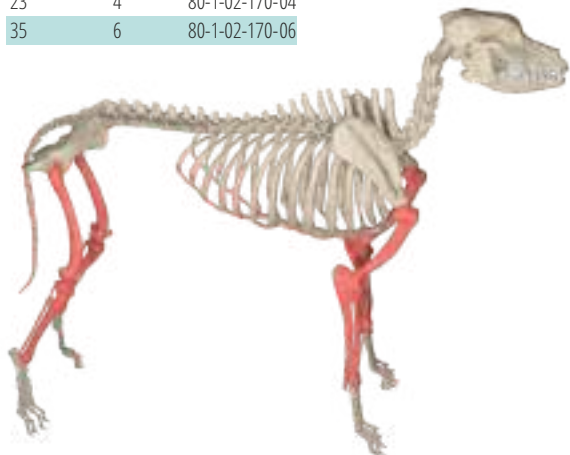

CORTICAL SCREWS
self-tapping \varnothing 2,0



L (mm)	REF
6-40 step 2mm	80-1-01-45-L

LOCKING SCREWS
self-tapping \varnothing 2,0



L (mm)	REF
6-40 step 2mm	80-1-01-260-L

DRILL \varnothing 1.5mm
DRILL GUIDE 80-4-57-191-00
SCREWDRIVER 80-4-43-33-02.1
HANDLE 80-28-5-1
SHAFT \leq 1,5 80-28-5-2

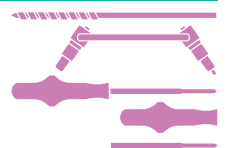

DRILL \varnothing 1.5mm
HOLDING SLEEVE 80-4-57-122-00
SCREWDRIVER 80-4-43-33-02.1
HANDLE 80-28-5-1
SHAFT \leq 1,5 80-28-5-2

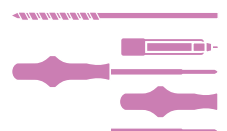

LOCKING - COMPRESSION PLATE
TITANIUM | STEEL

cortical screw \varnothing 2,0 mm

locking screw \varnothing 2,0 mm

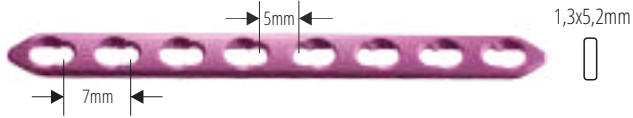

L (mm)	holes	REF No.	L (mm)	holes	REF No.
24	3	80-X-02-166-03	59	8	80-X-02-166-08
31	4	80-X-02-166-04	73	10	80-X-02-166-10
38	5	80-X-02-166-05	87	12	80-X-02-166-12
45	6	80-X-02-166-06	101	14	80-X-02-166-14
52	7	80-X-02-166-07	115	16	80-X-02-166-16



CORTICAL SCREWS
self-tapping \varnothing 2,0



L (mm)	REF
6-40 step 2mm	80-X-01-45-L

LOCKING SCREWS
self-tapping \varnothing 2,0



L (mm)	REF
6-40 step 2mm	80-X-01-260-L

DRILL \varnothing 1.5mm
DRILL GUIDE 80-4-57-191-00
SCREWDRIVER 80-4-43-33-02.1
HANDLE 80-28-5-1
SHAFT \leq 1,5 80-28-5-2

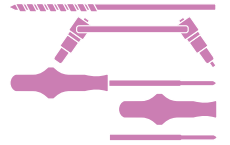

DRILL \varnothing 1.5mm
HOLDING SLEEVE 80-4-57-122-00
SCREWDRIVER 80-4-43-33-02.1
HANDLE 80-28-5-1
SHAFT \leq 1,5 80-28-5-2

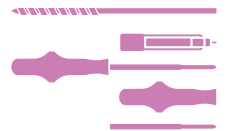

RECONSTRUCTION LOCKING COMPRESSION PLATE
TITANIUM | STEEL

cortical screws \varnothing 2,0 mm

locking screws \varnothing 2,0 mm

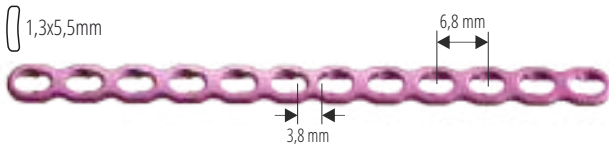

L (mm)	holes	REF No.
27	4	80-X-02-169-04
40	6	80-X-02-169-06
54	8	80-X-02-169-08
67	10	80-X-02-169-10
81	12	80-X-02-169-12
95	14	80-X-02-169-14
109	16	80-X-02-169-16

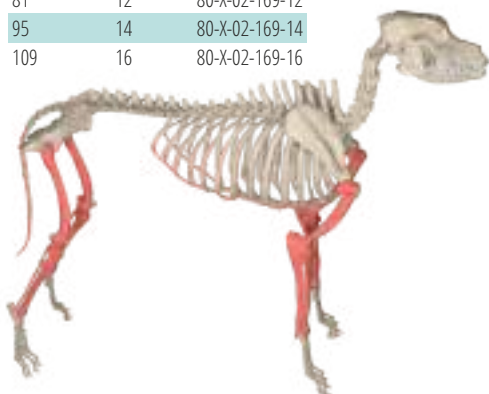

CORTICAL SCREWS
self-tapping \varnothing 2,0



L (mm)	REF
6-40 step 2mm	80-X-01-45-L

LOCKING SCREWS
self-tapping \varnothing 2,0



L (mm)	REF
6-40 step 2mm	80-X-01-260-L

DRILL \varnothing 1.5mm
DRILL GUIDE 80-4-57-191-00
SCREWDRIVER 80-4-43-33-02.1
HANDLE 80-28-5-1
SHAFT \leq 1,5 80-28-5-2

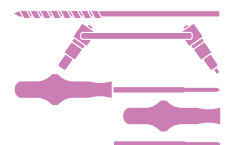

DRILL \varnothing 1.5mm
HOLDING SLEEVE 80-4-57-122-00
SCREWDRIVER 80-4-43-33-02.1
HANDLE 80-28-5-1
SHAFT \leq 1,5 80-28-5-2



**PLATE -L2- 120°
TITANIUM**

locking screws \varnothing 2,0 mm

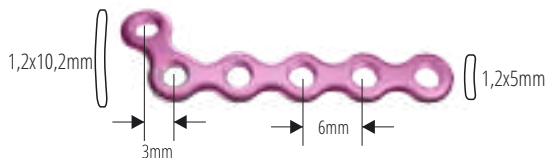

L (mm)	holes	LEFT	RIGHT
32	4	80-1-04-323-04	80-1-04-324-04



**LOCKING SCREWS
self-tapping \varnothing 2,0**



L (mm)	REF
6-40 step 2mm	80-1-01-260-L

DRILL \varnothing 1.5mm
HOLDING SLEEVE 80-4-57-122-00
SCREWDRIVER 80-4-43-33-02.1
HANDLE 80-28-5-1
SHAFT \leq 1,5 80-28-5-2

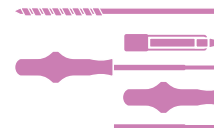

**PLATE - T2
TITANIUM**

locking screws \varnothing 2,0 mm

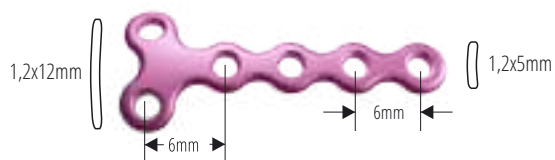

L (mm)	holes	REF No.
30	4	80-1-04-255-04



**LOCKING SCREWS
self-tapping \varnothing 2,0**

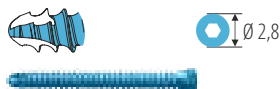

L (mm)	REF
6-40 step 2mm	80-1-01-260-L

DRILL \varnothing 1.5mm
HOLDING SLEEVE 80-4-57-122-00
SCREWDRIVER 80-4-43-33-02.1
HANDLE 80-28-5-1
SHAFT \leq 1,5 80-28-5-2

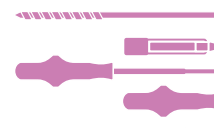

**PLATE -T
TITANIUM**

cortical screws \varnothing 2,0 mm
locking screws \varnothing 2,0 mm



L (mm)	holes	REF No.
52,5	7	80-1-04-269-07

**CORTICAL SCREWS
self-tapping \varnothing 2,0**



L (mm)	REF
6-40 step 2mm	80-1-01-45-L

**LOCKING SCREWS
self-tapping \varnothing 2,0**



L (mm)	REF
6-40 step 2mm	80-1-01-260-L

DRILL \varnothing 1.5mm
DRILL GUIDE 80-4-57-191-00
SCREWDRIVER 80-4-43-33-02.1
HANDLE 80-28-5-1
SHAFT \leq 1,5 80-28-5-2

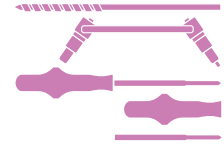

DRILL \varnothing 1.5mm
HOLDING SLEEVE 80-4-57-122-00
SCREWDRIVER 80-4-43-33-02.1
HANDLE 80-28-5-1
SHAFT \leq 1,5 80-28-5-2

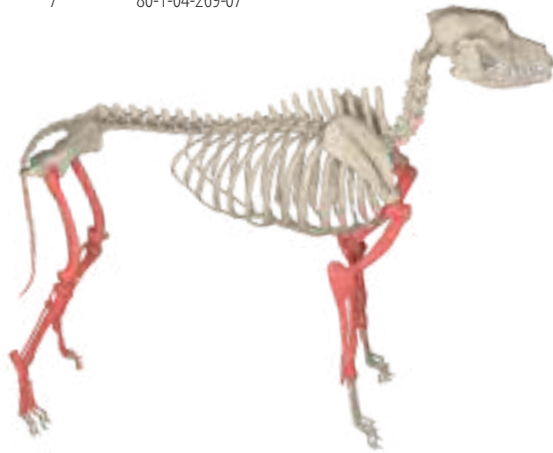
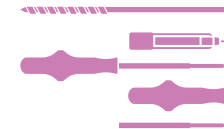

**PLATES -T 3
TITANIUM**

locking screws \varnothing 2,0 mm

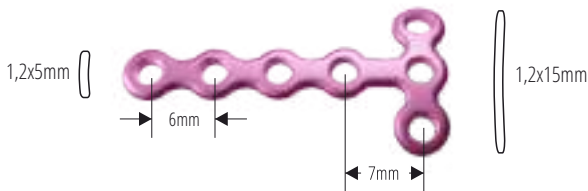

L (mm)	holes	REF No.
30	4	80-1-04-257-04

**LOCKING SCREWS
self-tapping \varnothing 2,0**



L (mm)	REF
6-40 step 2mm	80-1-01-260-L

DRILL \varnothing 1.5mm
HOLDING SLEEVE 80-4-57-122-00
SCREWDRIVER 80-4-43-33-02.1
HANDLE 80-28-5-1
SHAFT \leq 1,5 80-28-5-2

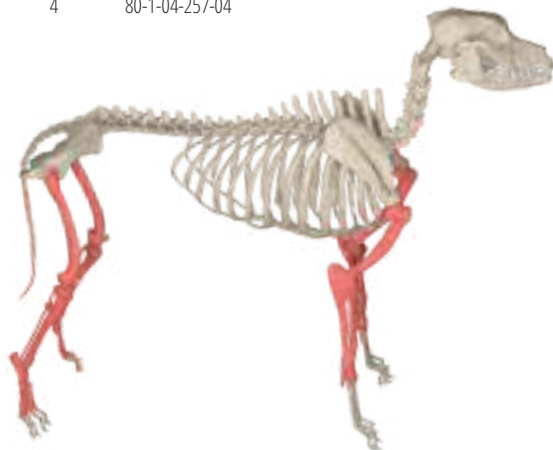
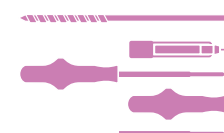

**CONDYLAR PLATE - T
TITANIUM**

cortical screws \varnothing 2,0 mm
locking screws \varnothing 2,0 mm



L (mm)	holes	REF No.
26,8	3	80-1-04-264-03
33,6	4	80-1-04-264-04
40,4	5	80-1-04-264-05
47,2	6	80-1-04-264-06
54,0	7	80-1-04-264-07

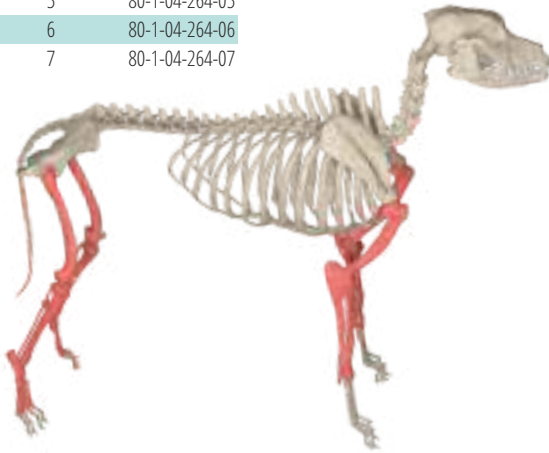

**CORTICAL SCREWS
self-tapping \varnothing 2,0**



L (mm)	REF
6-40 step 2mm	80-1-01-45-L

**LOCKING SCREWS
self-tapping \varnothing 2,0**

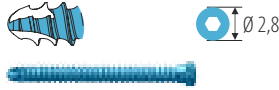

L (mm)	REF
6-40 step 2mm	80-1-01-260-L

DRILL \varnothing 1.5mm
DRILL GUIDE 80-4-57-191-00
SCREWDRIVER 80-4-43-33-02.1
HANDLE 80-28-5-1
SHAFT \leq 1,5 80-28-5-2

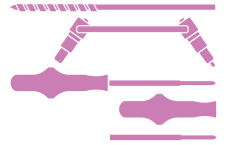

DRILL \varnothing 1.5mm
HOLDING SLEEVE 80-4-57-122-00
SCREWDRIVER 80-4-43-33-02.1
HANDLE 80-28-5-1
SHAFT \leq 1,5 80-28-5-2

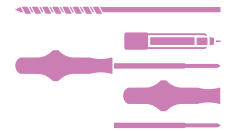

**LOCKING COMPRESSION T3 PLATE
TITANIUM**

cortical screws \varnothing 2,0 mm
locking screws \varnothing 2,0 mm

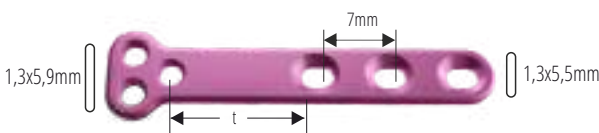

L (mm)	holes	t	REF No.
37	6	13,5	80-1-25-35-01
43	7	12,5	80-1-25-35-02
50	7	19,5	80-1-25-35-03

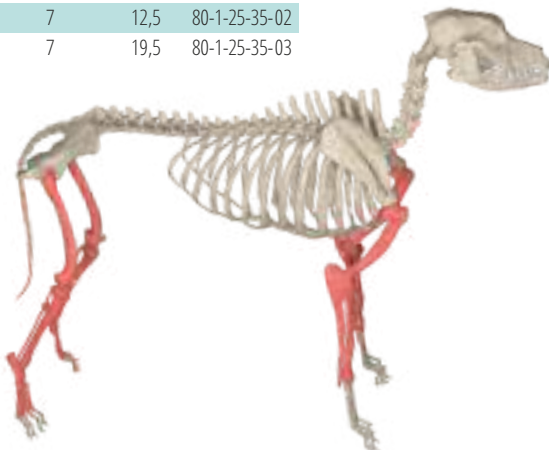

**CORTICAL SCREWS
self-tapping \varnothing 2,0**



L (mm)	REF
6-40 step 2mm	80-1-01-45-L

**LOCKING SCREWS
self-tapping \varnothing 2,0**



L (mm)	REF
6-40 step 2mm	80-1-01-260-L

DRILL \varnothing 1.5mm
DRILL GUIDE 80-4-57-191-00
SCREWDRIVER 80-4-43-33-02.1
HANDLE 80-28-5-1
SHAFT \leq 1,5 80-28-5-2

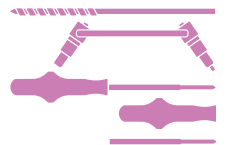

DRILL \varnothing 1.5mm
HOLDING SLEEVE 80-4-57-122-00
SCREWDRIVER 80-4-43-33-02.1
HANDLE 80-28-5-1
SHAFT \leq 1,5 80-28-5-2

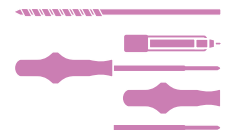

**LOCKING COMPRESSION PLATE FOR OSTEOTOMIES
TITANIUM**

cortical screws \varnothing 2,0 mm
locking screws \varnothing 2,0 mm



L (mm)	holes	REF No.
34	4	80-1-04-261-04
40	5	80-1-04-261-05

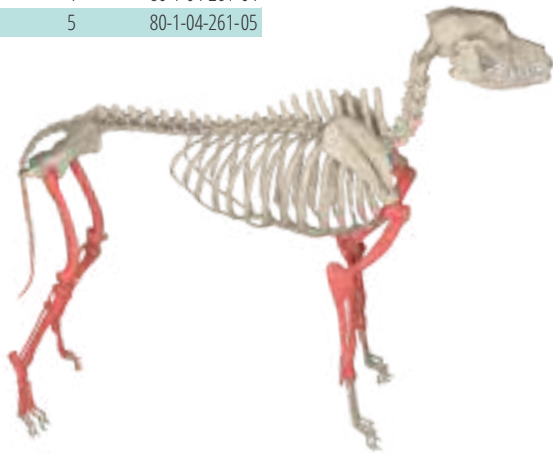

**CORTICAL SCREWS
self-tapping \varnothing 2,0**



L (mm)	REF
6-40 step 2mm	80-1-01-45-L

**LOCKING SCREWS
self-tapping \varnothing 2,0**



L (mm)	REF
6-40 step 2mm	80-1-01-260-L

DRILL \varnothing 1.5mm
DRILL GUIDE 80-4-57-191-00
SCREWDRIVER 80-4-43-33-02.1
HANDLE 80-28-5-1
SHAFT s1,5 80-28-5-2

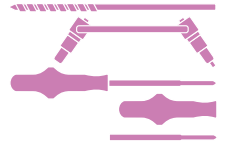

DRILL \varnothing 1.5mm
HOLDING SLEEVE 80-4-57-122-00
SCREWDRIVER 80-4-43-33-02.1
HANDLE 80-28-5-1
SHAFT s1,5 80-28-5-2

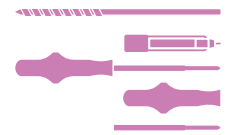

**LOCKING COMPRESSION PLATE FOR OSTEOTOMIES
TITANIUM**

cortical screws \varnothing 2,0 mm
locking screws \varnothing 2,0 mm



L (mm)	holes	REF No.
27	4	80-1-04-262-04
32	5	80-1-04-262-05



**CORTICAL SCREWS
self-tapping \varnothing 2,0**



L (mm)	REF
6-40 step 2mm	80-1-01-45-L

**LOCKING SCREWS
self-tapping \varnothing 2,0**

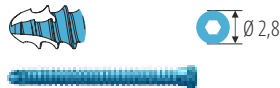

L (mm)	REF
6-40 step 2mm	80-1-01-260-L

DRILL \varnothing 1.5mm
DRILL GUIDE 80-4-57-191-00
SCREWDRIVER 80-4-43-33-02.1
HANDLE 80-28-5-1
SHAFT s1,5 80-28-5-2

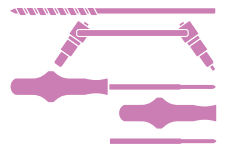

DRILL \varnothing 1.5mm
HOLDING SLEEVE 80-4-57-122-00
SCREWDRIVER 80-4-43-33-02.1
HANDLE 80-28-5-1
SHAFT s1,5 80-28-5-2

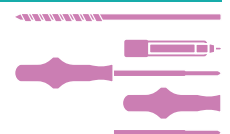

QUADRUPLE BRIDGE PLATE
TITANIUM

locking screws \varnothing 2,0 mm



L (mm)	holes	LEFT	RIGHT
23	8	80-1-04-285-00	80-1-04-286-00

LOCKING SCREWS
self-tapping \varnothing 2,0

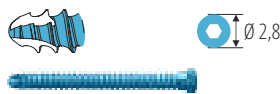

L (mm)	REF
6-40 step 2mm	80-1-01-260-L

DRILL \varnothing 1.5mm
HOLDING SLEEVE 80-4-57-122-00
SCREWDRIVER 80-4-43-33-02.1
HANDLE 80-28-5-1
SHAFT \leq 1,5 80-28-5-2

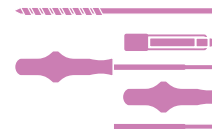
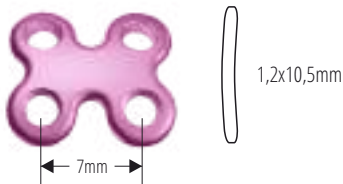

PLATE -H
TITANIUM

locking screws \varnothing 2,0 mm



L (mm)	holes	REF No.
12	4	80-1-04-260-04

LOCKING SCREWS
self-tapping \varnothing 2,0

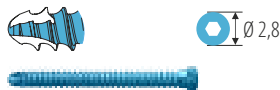

L (mm)	REF
6-40 step 2mm	80-1-01-260-L

DRILL \varnothing 1.5mm
HOLDING SLEEVE 80-4-57-122-00
SCREWDRIVER 80-4-43-33-02.1
HANDLE 80-28-5-1
SHAFT \leq 1,5 80-28-5-2

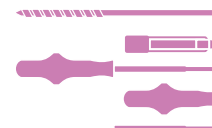

RECONSTRUCTION LOCKING PLATE
TITANIUM | STEEL

locking screws \varnothing 2,4 mm



L (mm)	holes	REF No.
48	6	80-X-02-185-06
64	8	80-X-02-185-08
80	10	80-X-02-185-10
96	12	80-X-02-185-12
112	14	80-X-02-185-14
128	16	80-X-02-185-16
144	18	80-X-02-185-18
160	20	80-X-02-185-20
176	22	80-X-02-185-22
192	24	80-X-02-185-24
208	26	80-X-02-185-26

LOCKING SCREWS
self-tapping \varnothing 2,4



L (mm)	REF
8-40 step 2mm	80-X-01-200-L

LOCKING SCREWS
multi-angle \varnothing 2,4



L (mm)	T8
8-40 step 2mm	80-X-01-298-L

LOCKING SCREWS
self-tapping \varnothing 2,7



L (mm)	REF
8-40 step 2mm	80-X-01-201-L

LOCKING SCREWS
multi-angle \varnothing 2,7



L (mm)	REF
10-40 step 2mm	80-X-01-325-L

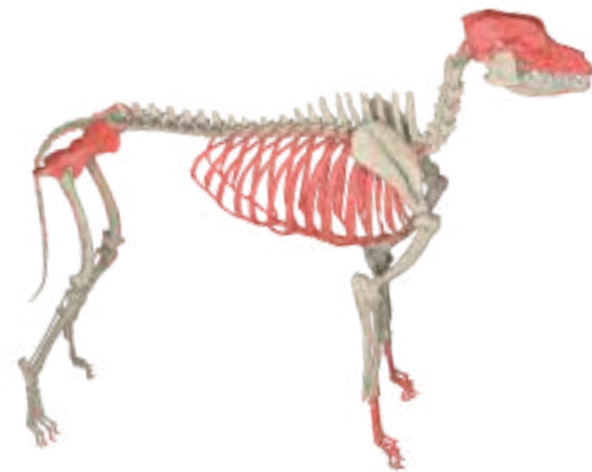

DRILL \varnothing 1.8mm
HOLDING SLEEVE 80-4-57-49-00
SCREWDRIVER 80-4-57-33-00
HANDLE 80-28-5-1
SHAFT s2,5 80-28-5-3



DRILL \varnothing 1.8mm
VARIABLE ANGLE SLEEVE 80-4-57-171-01
SCREWDRIVER T8 80-4-57-76-00
HANDLE 80-28-5-1
SHAFT T8 80-4-43-45-16.1



DRILL \varnothing 2.0mm
HOLDING SLEEVE 80-4-57-74-00
SCREWDRIVER 80-4-57-33-00
HANDLE 80-28-5-1
SHAFT s2,5 80-28-5-3



DRILL \varnothing 2.0mm
VARIABLE ANGLE SLEEVE 80-4-57-171-02
SCREWDRIVER T8 4-57-76-00
HANDLE 80-28-5-1
SHAFT 80-4-43-45-16.1



STRAIGHT RECONSTRUCTION PLATE
TITANIUM | STEEL

cortical screws \varnothing 3,5 mm

locking screws \varnothing 2,4/2,7 mm

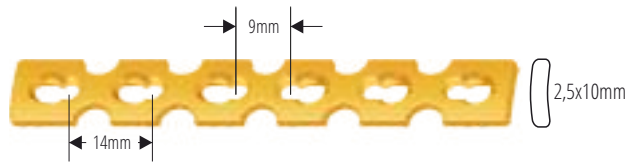

L (mm)	holes	REF No.
56	4	80-X-25-200-04
70	5	80-X-25-200-05
84	6	80-X-25-200-06
98	7	80-X-25-200-07
112	8	80-X-25-200-08
126	9	80-X-25-200-09
140	10	80-X-25-200-10
154	11	80-X-25-200-11
168	12	80-X-25-200-12
182	13	80-X-25-200-13
196	14	80-X-25-200-14
224	16	80-X-25-200-16
252	18	80-X-25-200-18
280	20	80-X-25-200-20
308	22	80-X-25-200-22

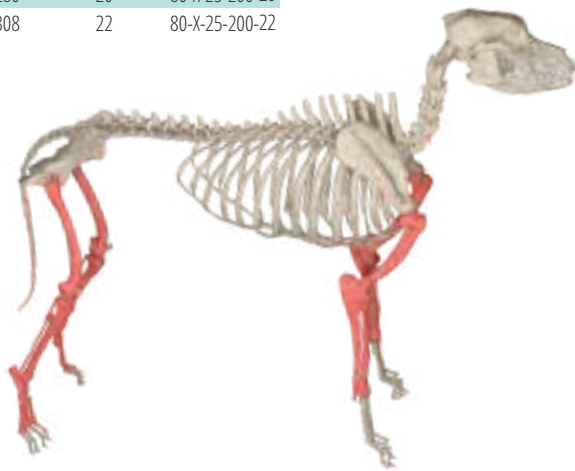

LOCKING SCREWS
self-tapping \varnothing 2,4



L (mm)	REF
8-40 step 2mm	80-X-01-200-L

LOCKING SCREWS
multi-angle \varnothing 2,4



L (mm)	T8
8-40 step 2mm	80-X-01-298-L

LOCKING SCREWS
self-tapping \varnothing 2,7



L (mm)	REF
8-40 step 2mm	80-X-01-201-L

LOCKING SCREWS
multi-angle \varnothing 2,7



L (mm)	REF
10-40 step 2mm	80-X-01-325-L

CORTICAL SCREWS
self-tapping \varnothing 3,5



L (mm)	REF
10-70 step 2mm	
70-90 step 5mm	80-X-01-51-L

DRILL \varnothing 1.8mm
HOLDING SLEEVE 80-4-57-49-00
SCREWDRIVER 80-4-57-33-00
HANDLE 80-28-5-1
SHAFT s2,5 80-28-5-3



DRILL \varnothing 1.8mm
VARIABLE ANGLE SLEEVE 80-4-57-171-01
SCREWDRIVER T8 80-4-57-76-00
HANDLE 80-28-5-1
SHAFT T8 80-4-43-45-16.1



DRILL \varnothing 2.0mm
HOLDING SLEEVE 80-4-57-74-00
SCREWDRIVER 80-4-57-33-00
HANDLE 80-28-5-1
SHAFT s2,5 80-28-5-3



DRILL \varnothing 2.0mm
VARIABLE ANGLE SLEEVE 80-4-57-171-02
SCREWDRIVER T8 4-57-76-00
HANDLE 80-28-5-1
SHAFT 80-4-43-45-16.1



DRILL \varnothing 2.5mm
DRILL GUIDE 80-4-57-191-00
SCREWDRIVER 80-4-57-33-00
HANDLE 80-28-5-1
SHAFT s2,5 80-28-5-3

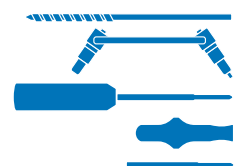

RECONSTRUCTION LOCKING COMPRESSION PLATE
TITANIUM|STEEL

cortical screws \varnothing 2,4/2,7 mm

locking screws \varnothing 2,4/2,7 mm

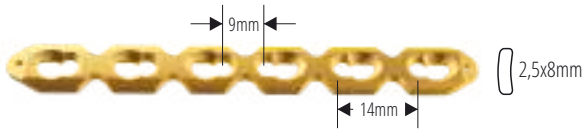

L (mm)	holes	REF No.
56	4	80-X-02-183-04
70	5	80-X-02-183-05
84	6	80-X-02-183-06
98	7	80-X-02-183-07
112	8	80-X-02-183-08
126	9	80-X-02-183-09
140	10	80-X-02-183-10
154	11	80-X-02-183-11
168	12	80-X-02-183-12
196	14	80-X-02-183-14
224	16	80-X-02-183-16
252	18	80-X-02-183-18
280	20	80-X-02-183-20



LOCKING SCREWS

self-tapping \varnothing 2,4



L (mm) **REF**
8-60 |step 2mm 80-X-01-239-L

LOCKING SCREWS

SELF-TAPPING \varnothing 2,4



L (mm) **REF**
8-40 |step 2mm 80-X-01-200-L

LOCKING SCREWS

multi-angle \varnothing 2,4



L (mm) **T8**
8-40 |step 2mm 80-X-01-298-L

CORTICAL SCREWS

self-tapping \varnothing 2,7



L (mm) **REF**
8-60 |step 2mm 80-X-01-48-L

LOCKING SCREWS

self-tapping \varnothing 2,7



L (mm) **REF**
8-40 |step 2mm 80-X-01-201-L

LOCKING SCREWS

multi-angle \varnothing 2,7



L (mm) **REF**
10-40 |step 2mm 80-X-01-325-L

DRILL \varnothing 1.8mm
DRILL GUIDE 80-4-57-183-00
SCREWDRIVER 80-4-57-33-00
HANDLE 80-28-5-1
SHAFT s2,5 80-28-5-3



DRILL \varnothing 1.8mm
HOLDING SLEEVE 80-4-57-49-00
SCREWDRIVER 80-4-57-33-00
HANDLE 80-28-5-1
SHAFT s2,5 80-28-5-3



DRILL \varnothing 1.8mm
VARIABLE ANGLE SLEEVE 80-4-57-171-01
SCREWDRIVER T8 80-4-57-76-00
HANDLE 80-28-5-1
SHAFT T8 80-4-43-45-16.1



DRILL \varnothing 2.0mm
DRILL GUIDE 80-4-57-192-00
SCREWDRIVER 80-4-57-33-00
HANDLE 80-28-5-1
SHAFT s2,5 80-28-5-3



DRILL \varnothing 2.0mm
HOLDING SLEEVE 80-4-57-74-00
WKREŹAK 80-4-57-33-00
HANDLE 80-28-5-1
SHAFT s2,5 80-28-5-3



DRILL \varnothing 2.0mm
VARIABLE ANGLE SLEEVE 80-4-57-171-02
SCREWDRIVER T8 4-57-76-00
HANDLE 80-28-5-1
SHAFT 80-4-43-45-16.1



LOCKING COMPRESSION PLATE WITH LIMITED CONTACT TITANIUM

cortical screws \varnothing 2,4/2,7 mm

locking screws \varnothing 2,4/2,7 mm

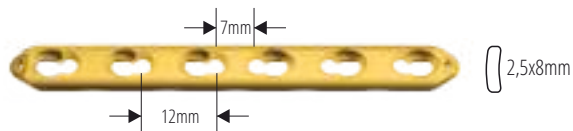

L (mm)	holes	REF No.
50	4	80-1-02-200-04
62	5	80-1-02-200-05
74	6	80-1-02-200-06
86	7	80-1-02-200-07
98	8	80-1-02-200-08
110	9	80-1-02-200-09
122	10	80-4-02-200-10
134	11	80-1-02-200-11
146	12	80-1-02-200-12
170	14	80-1-02-200-14
194	16	80-1-02-200-16
218	18	80-1-02-200-18
242	20	80-1-02-200-20

CORTICAL SCREWS self-tapping \varnothing 2,4



L (mm)	REF
8-60 step 2mm	80-1-01-239-L

LOCKING SCREWS self-tapping \varnothing 2,4



L (mm)	REF
8-40 step 2mm	80-1-01-200-L

LOCKING SCREWS multi-angle \varnothing 2,4



L (mm)	T8
8-40 step 2mm	80-1-01-298-L

CORTICAL SCREWS self-tapping \varnothing 2,7



L (mm)	REF
8-60 step 2mm	80-1-01-48-L

LOCKING SCREWS self-tapping \varnothing 2,7



L (mm)	REF
8-40 step 2mm	80-1-01-201-L

LOCKING SCREWS multi-angle \varnothing 2,7



L (mm)	REF
10-40 step 2mm	80-1-01-325-L

DRILL \varnothing 1.8mm
 DRILL GUIDE 80-4-57-183-00
 SCREWDRIVER 80-4-57-33-00
 HANDLE 80-28-5-1
 SHAFT s2,5 80-28-5-3

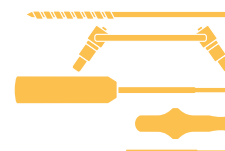

DRILL \varnothing 1.8mm
 HOLDING SLEEVE 80-4-57-49-00
 SCREWDRIVER 80-4-57-33-00
 HANDLE 80-28-5-1
 SHAFT s2,5 80-28-5-3



DRILL \varnothing 1.8mm
 VARIABLE ANGLE SLEEVE 80-4-57-171-01
 SCREWDRIVER T8 80-4-57-76-00
 HANDLE 80-28-5-1
 SHAFT T8 80-4-43-45-16.1



DRILL \varnothing 2.0mm
 DRILL GUIDE 80-4-57-192-00
 SCREWDRIVER 80-4-57-33-00
 HANDLE 80-28-5-1
 SHAFT s2,5 80-28-5-3



DRILL \varnothing 2.0mm
 HOLDING SLEEVE 80-4-57-74-00
 SCREWDRIVER 80-4-57-33-00
 HANDLE 80-28-5-1
 SHAFT s2,5 80-28-5-3



DRILL \varnothing 2.0mm
 VARIABLE ANGLE SLEEVE 80-4-57-171-02
 SCREWDRIVER T8 4-57-76-00
 HANDLE 80-28-5-1
 SHAFT 80-4-43-45-16.1



**RECONSTRUCTION LOCKING COMPRESSION PLATE WITH LIMITED CONTACT
TITANIUM**

cortical screws \varnothing 2,4/2,7 mm

locking screws \varnothing 2,4/2,7 mm

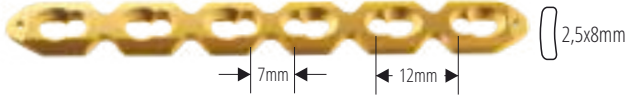

L (mm)	holes	REF No.
50	4	80-1-02-184-04
62	5	80-1-02-184-05
74	6	80-1-02-184-06
86	7	80-1-02-184-07
98	8	80-1-02-184-08
110	9	80-1-02-184-09
122	10	80-1-02-184-10
134	11	80-1-02-184-11
146	12	80-1-02-184-12
170	14	80-1-02-184-14
194	16	80-1-02-184-16
218	18	80-1-02-184-18
242	20	80-1-02-184-20

CORTICAL SCREWS

self-tapping \varnothing 2,4



L (mm)	REF
8-60 step 2mm	80-1-01-239-L

LOCKING SCREWS

self-tapping \varnothing 2,4



L (mm)	REF
8-40 step 2mm	80-1-01-200-L

LOCKING SCREWS

multi-angle \varnothing 2,4



L (mm)	T8
8-40 step 2mm	80-1-01-298-L

CORTICAL SCREWS

self-tapping \varnothing 2,7



L (mm)	REF
8-60 step 2mm	80-1-01-48-L

LOCKING SCREWS

self-tapping \varnothing 2,7



L (mm)	REF
8-40 step 2mm	80-1-01-201-L

LOCKING SCREWS

multi-angle \varnothing 2,7



L (mm)	REF
10-40 step 2mm	80-1-01-325-L

DRILL \varnothing 1.8mm
DRILL GUIDE 80-4-57-183-00
SCREWDRIVER 80-4-57-33-00
HANDLE 80-28-5-1
SHAFT s2,5 80-28-5-3



DRILL \varnothing 1.8mm
HOLDING SLEEVE 80-4-57-49-00
SCREWDRIVER 80-4-57-33-00
HANDLE 80-28-5-1
SHAFT s2,5 80-28-5-3



DRILL \varnothing 1.8mm
VARIABLE ANGLE SLEEVE 80-4-57-171-01
SCREWDRIVER T8 80-4-57-76-00
HANDLE 80-28-5-1
SHAFT T8 80-4-43-45-16.1



DRILL \varnothing 2.0mm
DRILL GUIDE 80-4-57-192-00
SCREWDRIVER 80-4-57-33-00
HANDLE 80-28-5-1
SHAFT s2,5 80-28-5-3

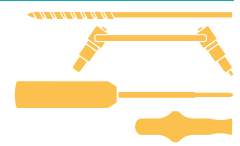

DRILL \varnothing 2.0mm
HOLDING SLEEVE 80-4-57-74-00
SCREWDRIVER 80-4-57-33-00
HANDLE 80-28-5-1
SHAFT s2,5 80-28-5-3



DRILL \varnothing 2.0mm
VARIABLE ANGLE SLEEVE 80-4-57-171-02
SCREWDRIVER T8 80-4-57-76-00
HANDLE 80-28-5-1
SHAFT 80-4-43-45-16.1

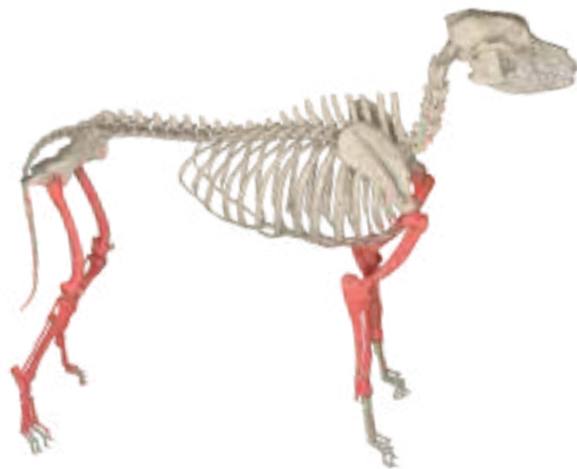

**LOCKING RECONSTRUCTION PLATE
TITANIUM**

locking screws \varnothing 3,5 mm

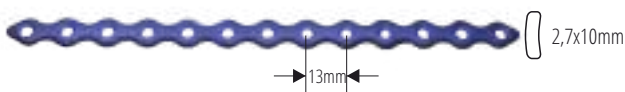

L (mm)	holes	REF No.	L (mm)	holes	REF No.
39	3	80-1-02-152-03	130	10	80-1-02-152-10
52	4	80-1-02-152-04	143	11	80-1-02-152-11
65	5	80-1-02-152-05	156	12	80-1-02-152-12
78	6	80-1-02-152-06	169	13	80-1-02-152-13
91	7	80-1-02-152-07	182	14	80-1-02-152-14
104	8	80-1-02-152-08	195	15	80-1-02-152-15
117	9	80-1-02-152-09	208	16	80-1-02-152-16



**LOCKING SCREWS
self-tapping \varnothing 3,5**



L (mm)	REF
10-60 step 2mm	80-1-01-11-L
70-95 step 5mm	

**LOCKING SCREWS
multi-angle \varnothing 3,5**



L (mm)	REF
10-60 step 2mm	80-1-01-322-L
60-95 step 5mm	

DRILL \varnothing 2.7mm
HOLDING SLEEVE 80-4-57-51-00
SCREWDRIVER 80-4-57-33-00
HANDLE 80-28-5-1
SHAFT s2,5 80-28-5-3



DRILL \varnothing 2.7mm
VARIABLE ANGLE SLEEVE 80-4-57-171-03
SCREWDRIVER T15 80-4-57-181-00
HANDLE 80-28-5-1
SHAFT T15 80-4-43-45-22.1

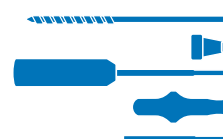

**LOCKING COMPRESSION PLATE
WITH LIMITED CONTACT
TITANIUM | STEEL**

cortical screws \varnothing 3,5 mm

locking screws \varnothing 3,5 mm

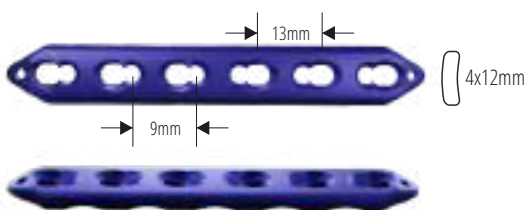

L (mm)	holes	REF No.	L (mm)	holes	REF No.
59	4	80-X-02-117-04	150	11	80-X-02-117-11
72	5	80-X-02-117-05	163	12	80-X-02-117-12
85	6	80-X-02-117-06	189	14	80-X-02-117-14
98	7	80-X-02-117-07	215	16	80-X-02-117-16
111	8	80-X-02-117-08	241	18	80-X-02-117-18
124	9	80-X-02-117-09	267	20	80-X-02-117-20
137	10	80-X-02-117-10			



**CORTICAL SCREWS
self-tapping \varnothing 3,5**



L (mm)	REF
10-70 step 2mm	80-X-01-51-L
70-90 step 5mm	

**LOCKING SCREWS
self-tapping \varnothing 3,5**



L (mm)	REF
10-60 step 2mm	80-X-01-11-L
70-95 step 5mm	

**LOCKING SCREWS
multi-angle \varnothing 3,5**



L (mm)	REF
10-60 step 2mm	80-X-01-322-L
60-95 step 5mm	

DRILL \varnothing 2.5mm
DRILL GUIDE 80-4-57-191-00
SCREWDRIVER 80-4-57-33-00
HANDLE 80-28-5-1
SHAFT 80-28-5-3

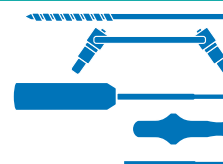

DRILL \varnothing 2.7mm
HOLDING SLEEVE 80-4-57-51-00
SCREWDRIVER 80-4-57-33-00
HANDLE 80-28-5-1
SHAFT s2,5 80-28-5-3

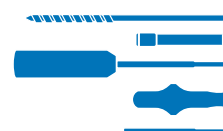

DRILL \varnothing 2.7mm
VARIABLE ANGLE SLEEVE 80-4-57-171-03
SCREWDRIVER T15 80-4-57-181-00
HANDLE 80-28-5-1
SHAFT T15 80-4-43-45-22.1

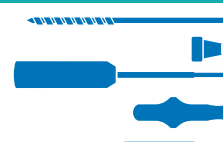

NARROW LOCKING COMPRESSION PLATE WITH LIMITED CONTACT, THICK TITANIUM

cortical screws \varnothing 3,5 mm
locking screws \varnothing 3,5 mm

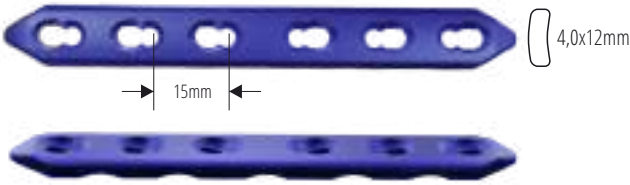

L (mm)	holes	REF No.	L (mm)	holes	REF No.
85	5	80-1-02-116-05	160	10	80-1-02-116-10
115	7	80-1-02-116-07	175	11	80-1-02-116-11
130	8	80-1-02-116-08	190	12	80-1-02-116-12
145	9	80-1-02-116-09	220	14	80-1-02-116-14



CORTICAL SCREWS self-tapping \varnothing 3,5



L (mm)	REF
10-70 step 2mm	
70-90 step 5mm	80-1-01-51-L

LOCKING SCREWS self-tapping \varnothing 3,5



L (mm)	REF
10-60 step 2mm	
70-95 step 5mm	80-1-01-11-L

LOCKING SCREWS multi-angle \varnothing 3,5



L (mm)	REF
10-60 step 2mm	
60-95 step 5mm	80-1-01-322-L

DRILL \varnothing 2.5mm
DRILL GUIDE 80-4-57-191-00
SCREWDRIVER 80-4-57-33-00
HANDLE 80-28-5-1
SHAFT 80-28-5-3

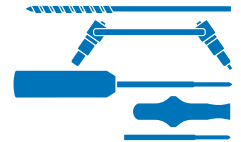

DRILL \varnothing 2.7mm
HOLDING SLEEVE 80-4-57-51-00
SCREWDRIVER 80-4-57-33-00
HANDLE 80-28-5-1
SHAFT s2,5 80-28-5-3



DRILL \varnothing 2.7mm
VARIABLE ANGLE SLEEVE 80-4-57-171-03
SCREWDRIVER T15 80-4-57-181-00
HANDLE 80-28-5-1
SHAFT T15 80-4-43-45-22.1



RECONSTRUCTION PLATE TITANIUM|STEEL

cortical screws \varnothing 3,5 mm
locking screws \varnothing 3,5 mm

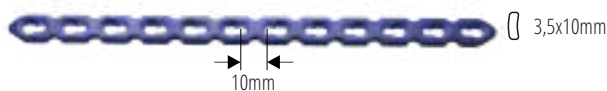

L (mm)	holes	REF No.
70	5	80-X-02-66-05
84	6	80-X-02-66-06
99	7	80-X-02-66-07
113	8	80-X-02-66-08
128	9	80-X-02-66-09
142	10	80-X-02-66-10
171	12	80-X-02-66-12



CORTICAL SCREWS self-tapping \varnothing 3,5



L (mm)	REF
10-70 step 2mm	
70-90 step 5mm	80-X-01-51-L

LOCKING SCREWS self-tapping \varnothing 3,5



L (mm)	REF
10-60 step 2mm	
70-95 step 5mm	80-X-01-11-L

LOCKING SCREWS multi-angle \varnothing 3,5



L (mm)	REF
10-60 step 2mm	
60-95 step 5mm	80-X-01-322-L

DRILL \varnothing 2.5mm
DRILL GUIDE 80-4-57-191-00
SCREWDRIVER 80-4-57-33-00
HANDLE 80-28-5-1
SHAFT 80-28-5-3

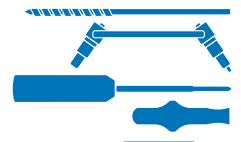

DRILL \varnothing 2.7mm
HOLDING DRILL 80-4-57-51-00
SCREWDRIVER 80-4-57-33-00
HANDLE 80-28-5-1
SHAFT s2,5 80-28-5-3



DRILL \varnothing 2.7mm
VARIABLE ANGLE SLEEVE 80-4-57-171-03
SCREWDRIVER T15 80-4-57-181-00
HANDLE 80-28-5-1
SHAFT T15 80-4-43-45-22.1

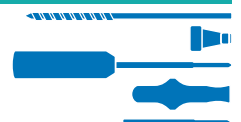

**TUBULAR PLATE
TITANIUM**

locking screws \varnothing 3,5 mm

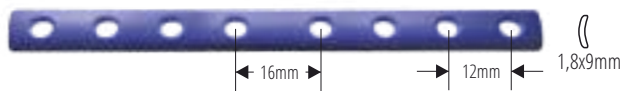

L (mm)	holes	REF No.
52	4	80-1-02-147-04
64	5	80-1-02-147-05
76	6	80-1-02-147-06
88	7	80-1-02-147-07
100	8	80-1-02-147-08
112	9	80-1-02-147-09
124	10	80-1-02-147-10
148	12	80-1-02-147-12

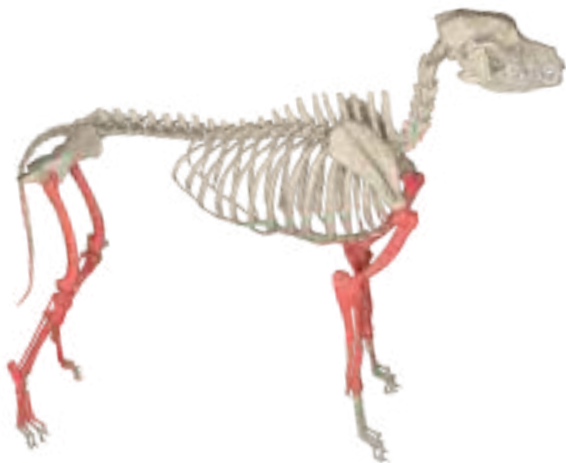

**LOCKING SCREWS
self-tapping \varnothing 3,5**



L (mm)	REF
10-60 step 2mm	80-1-01-11-L
70-95 step 5mm	

**LOCKING SCREWS
multi-angle \varnothing 3,5**



L (mm)	REF
10-60 step 2mm	80-1-01-322-L
60-95 step 5mm	

DRILL \varnothing 2.7mm
HOLDING SLEEVE 80-4-57-51-00
SCREWDRIVER 80-4-57-33-00
HANDLE 80-28-5-1
SHAFT s2,5 80-28-5-3



DRILL \varnothing 2.7mm
VARIABLE ANGLE SLEEVE 80-4-57-171-03
SCREWDRIVER T15 80-4-57-181-00
HANDLE 80-28-5-1
SHAFT T15 80-4-43-45-22.1

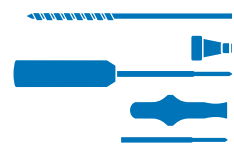

**RECONSTRUCTION LOCKING COMPRESSION PLATE
TITANIUM**

cortical screws \varnothing 3,5 mm

locking screws \varnothing 3,5 mm

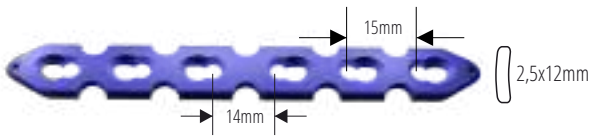

L (mm)	holes	REF No.	L (mm)	holes	REF No.
100	6	80-1-02-03-06	220	14	80-1-02-03-14
130	8	80-1-02-03-08	250	16	80-1-02-03-16
145	9	80-1-02-03-09	280	18	80-1-02-03-18
160	10	80-1-02-03-10	310	20	80-1-02-03-20
190	12	80-1-02-03-12	325	21	80-1-02-03-21



**CORTICAL SCREWS
self-tapping \varnothing 3,5**



L (mm)	REF
10-70 step 2mm	
70-90 step 5mm	80-1-01-51-L

**LOCKING SCREWS
self-tapping \varnothing 3,5**



L (mm)	REF
10-60 step 2mm	
70-95 step 5mm	80-1-01-11-L

**LOCKING SCREWS
multi-angle \varnothing 3,5**



L (mm)	REF
10-60 step 2mm	
60-95 step 5mm	80-1-01-322-L

DRILL \varnothing 2.5mm
DRILL GUIDE 80-4-57-191-00
SCREWDRIVER 80-4-57-33-00
HANDLE 80-28-5-1
SHAFT 80-28-5-3

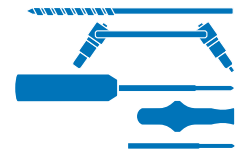

DRILL \varnothing 2.7mm
HOLDING SLEEVE 80-4-57-51-00
SCREWDRIVER 80-4-57-33-00
HANDLE 80-28-5-1
SHAFT s2,5 80-28-5-3



DRILL \varnothing 2.7mm
VARIABLE ANGLE SLEEVE 80-4-57-171-03
SCREWDRIVER T15 80-4-57-181-00
HANDLE 80-28-5-1
SHAFT T15 80-4-43-45-22.1



**METAPHYSEAL PLATE
TITANIUM**

cortical screws \varnothing 3,5 mm

locking screws \varnothing 3,5 mm

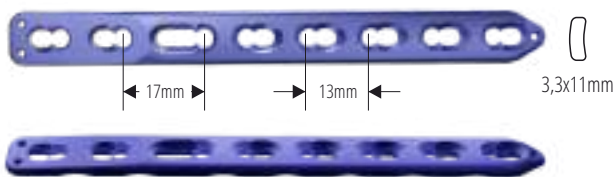

L (mm)	holes	REF No.	L (mm)	holes	REF No.
73	5	80-1-02-168-05	138	10	80-1-02-168-10
86	6	80-1-02-168-06	151	11	80-1-02-168-11
99	7	80-1-02-168-07	164	12	80-1-02-168-12
112	8	80-1-02-168-08	190	14	80-1-02-168-14
125	9	80-1-02-168-09	216	16	80-1-02-168-16



**CORTICAL SCREWS
self-tapping \varnothing 3,5**

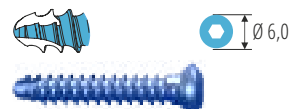

L (mm)	REF
10-70 step 2mm	
70-90 step 5mm	80-1-01-51-L

**LOCKING SCREWS
self-tapping \varnothing 3,5**

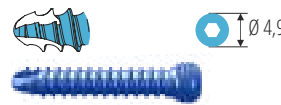

L (mm)	REF
10-60 step 2mm	
70-95 step 5mm	80-1-01-11-L

**LOCKING SCREWS
multi-angle \varnothing 3,5**



L (mm)	REF
10-60 step 2mm	
60-95 step 5mm	80-1-01-322-L

DRILL \varnothing 2.5mm
DRILL GUIDE 80-4-57-191-00
SCREWDRIVER 80-4-57-33-00
HANDLE 80-28-5-1
SHAFT 80-28-5-3

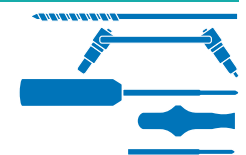

DRILL \varnothing 2.7mm
HOLDING SLEEVE 80-4-57-51-00
SCREWDRIVER 80-4-57-33-00
HANDLE 80-28-5-1
SHAFT s2,5 80-28-5-3



DRILL \varnothing 2.7mm
VARIABLE ANGLE SLEEVE 80-4-57-171-03
SCREWDRIVER T15 80-4-57-181-00
HANDLE 80-28-5-1
SHAFT T15 80-4-43-45-22.1



**SMALL PLATE
TITANIUM**

cortical screws \varnothing 2,0 mm

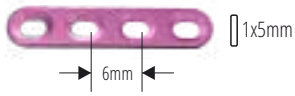

L (mm)	holes	REF No.	L (mm)	holes	REF No.
12	2	80-1-02-15-02	30	5	80-1-02-15-05
18	3	80-1-02-15-03	36	6	80-1-02-15-06
24	4	80-1-02-15-04	48	8	80-1-02-15-08

**CORTICAL SCREWS
self-tapping \varnothing 2,0**

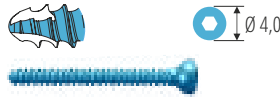

L (mm)	REF
6-40 step 2mm	80-1-01-45-L

DRILL \varnothing 1.5mm
DRILL GUIDE 80-4-57-191-00
SCREWDRIVER 80-4-43-33-02.1
HANDLE 80-28-5-1
SHAFT s1,5 80-28-5-2

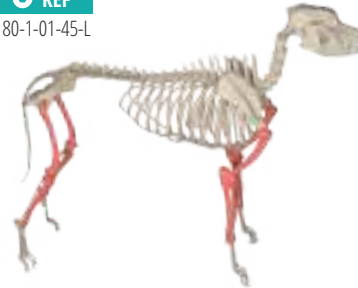
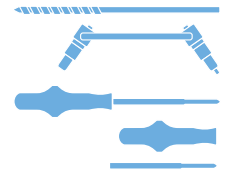

**SMALL PLATE
TITANIUM|STEEL**

cortical screws \varnothing 2,4/2,7 mm



L (mm)	holes	REF No.	L (mm)	holes	REF No.
32	4	80-X-02-13-04	88	11	80-X-02-13-11
40	5	80-X-02-13-05	96	12	80-X-02-13-12
48	6	80-X-02-13-06	104	13	80-X-02-13-13
56	7	80-X-02-13-07	112	14	80-X-02-13-14
64	8	80-X-02-13-08	120	15	80-X-02-13-15
72	9	80-X-02-13-09	128	16	80-X-02-13-16
80	10	80-X-02-13-10			

**CORTICAL SCREWS
self-tapping \varnothing 2,4**



L (mm)	REF
8-60 step 2mm	80-X-01-239-L

DRILL \varnothing 1.8mm
DRILL GUIDE 80-4-57-183-00
SCREWDRIVER 80-4-57-33-00
HANDLE 80-28-5-1
SHAFT s2,5 80-28-5-3

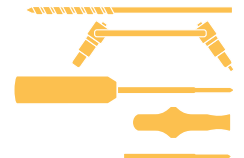

**CORTICAL SCREWS
self-tapping \varnothing 2,7**



L (mm)	REF
8-60 step 2mm	80-X-01-48-L

DRILL \varnothing 2.0mm
DRILL GUIDE 80-4-57-192-00
SCREWDRIVER 80-4-57-33-00
HANDLE 80-28-5-1
SHAFT s2,5 80-28-5-3

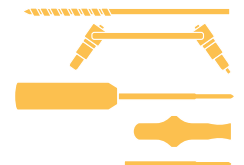

**STRAIGHT THIN PLATE WITH SEPARATE HOLES
TITANIUM|STEEL**

cortical screws \varnothing 2,0 mm

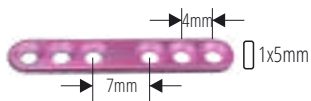

L (mm)	holes	REF No.	L (mm)	holes	REF No.
20	4	80-X-02-37-04	52	12	80-X-02-37-12
28	6	80-X-02-37-06	56	13	80-X-02-37-13
32	7	80-X-02-37-07	60	14	80-X-02-37-14
36	8	80-X-02-37-08	68	16	80-X-02-37-16
44	10	80-X-02-37-10			

**CORTICAL SCREWS
self-tapping \varnothing 2,0**

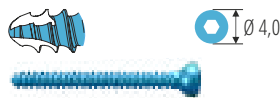

L (mm)	REF
6-40 step 2mm	80-X-01-45-L

DRILL \varnothing 1.5mm
DRILL GUIDE 80-4-57-191-00
SCREWDRIVER 80-4-43-33-02.1
HANDLE 80-28-5-1
SHAFT s1,5 80-28-5-2

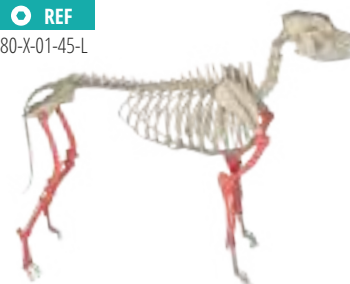
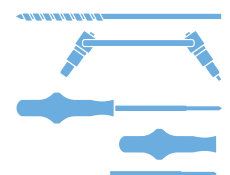

STRAIGHT PLATE WITH SEPARATE HOLES
TITANIUM | STEEL

cortical screws \varnothing 2,0 mm

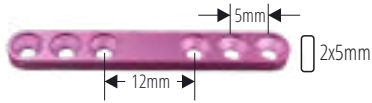

L (mm)	holes	REF No.
27	4	80-X-02-16-04
37	6	80-X-02-16-06
47	8	80-X-02-16-08
57	10	80-X-02-16-10
67	12	80-X-02-16-12

CORTICAL SCREWS
self-tapping \varnothing 2,0

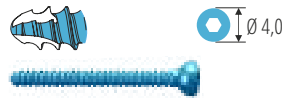

L (mm)	REF
6-40 step 2mm	80-X-01-45-L

DRILL \varnothing 1.5mm
HOLDING SLEEVE 80-4-57-191-00
SCREWDRIVER 80-4-43-33-02.1
HANDLE 80-28-5-1
SHAFT s1,5 80-28-5-2

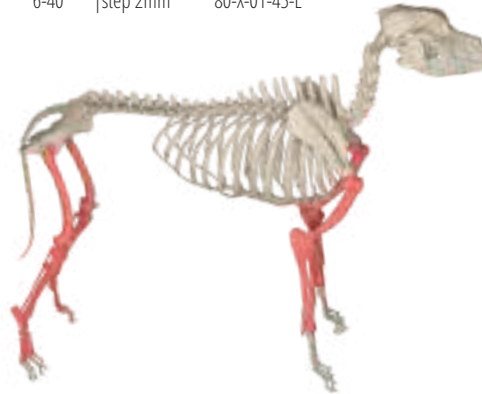
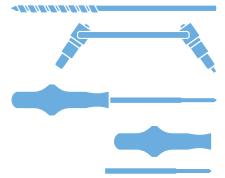

STRAIGHT PLATE WITH SEPARATE HOLES
TITANIUM | STEEL

cortical screws \varnothing 2,4/2,7 mm

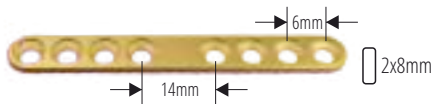

L (mm)	holes	REF No.
34	4	80-X-02-182-04
40	5	80-X-02-182-05
46	6	80-X-02-182-06
52	7	80-X-02-182-07
58	8	80-X-02-182-08
64	9	80-X-02-182-09
70	10	80-X-02-182-10
76	11	80-X-02-182-11
82	12	80-X-02-182-12
94	14	80-X-02-182-14
106	16	80-X-02-182-16
118	18	80-X-02-182-18

CORTICAL SCREWS
self-tapping \varnothing 2,4



L (mm)	REF
8-60 step 2mm	80-X-01-239-L

DRILL \varnothing 1.8mm
DRILL GUIDE 80-4-57-183-00
SCREWDRIVER 80-4-57-33-00
HANDLE 80-28-5-1
SHAFT s2,5 80-28-5-3

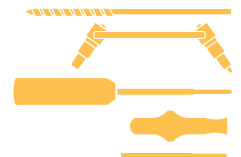

CORTICAL SCREWS
self-tapping \varnothing 2,7



L (mm)	REF
8-60 step 2mm	80-X-01-48-L

DRILL \varnothing 2.0mm
DRILL GUIDE 80-4-57-192-00
SCREWDRIVER 80-4-57-33-00
HANDLE 80-28-5-1
SHAFT s2,5 80-28-5-3

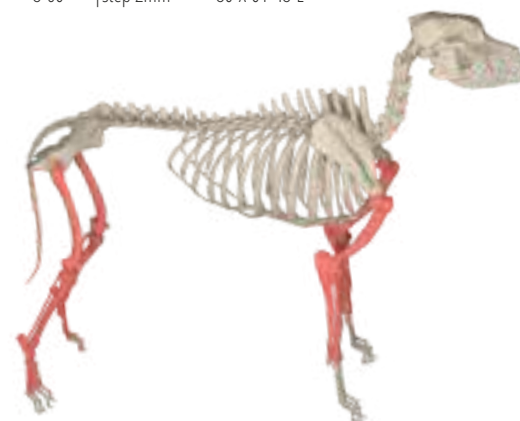
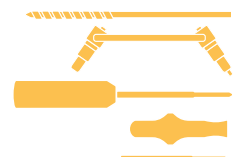

STRAIGHT PLATE WITH SEPARATE HOLES

TITANIUM | STEEL

cortical screws \varnothing 3,5mm

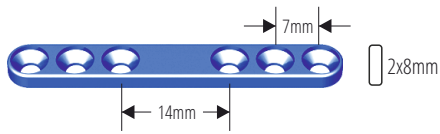

L (mm)	holes	REF No.	L (mm)	holes	REF No.
36	4	80-X-02-181-04	78	10	80-X-02-181-10
43	5	80-X-02-181-05	92	12	80-X-02-181-12
50	6	80-X-02-181-06	106	14	80-X-02-181-14
57	7	80-X-02-181-07	120	16	80-X-02-181-16
64	8	80-X-02-181-08	134	18	80-X-02-181-18
71	9	80-X-02-181-09	148	20	80-X-02-181-20

CORTICAL SCREWS

self-tapping \varnothing 3,5



L (mm)	step	REF
10-70	step 2mm	
70-90	step 5mm	80-X-01-51-L

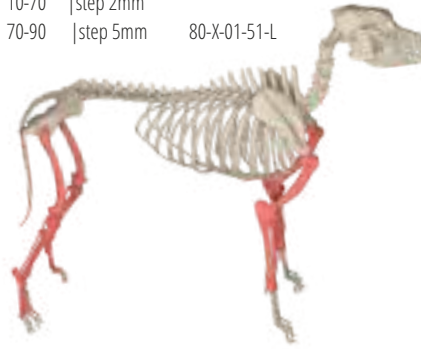

DRILL \varnothing 2.5mm
 DRILL GUIDE 80-4-57-191-00
 SCREWDRIVER 80-4-57-33-00
 HANDLE 80-28-5-1
 SHAFT 80-28-5-3

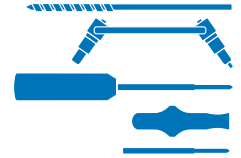

NARROW THIN PLATE

TITANIUM | STEEL

cortical screws \varnothing 4,5 mm

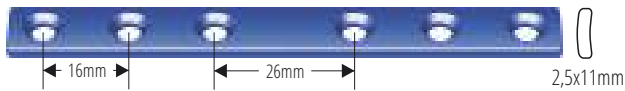

L (mm)	holes	REF No.
71	4	80-X-02-02-04
103	6	80-X-02-02-06
135	8	80-X-02-02-08

CORTICAL SCREWS

self-tapping \varnothing 4,5

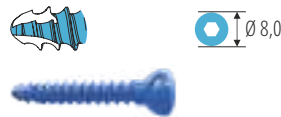

L (mm)	step	REF
12-80	step 2mm	80-X-01-04-L

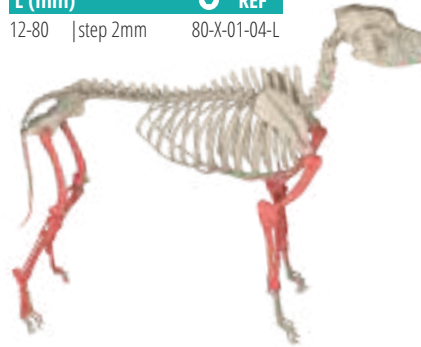

DRILL \varnothing 3.2mm 80-4-40-03-32
 DRILL GUIDE 80-4-57-57-00
 SCREWDRIVER S3,5 80-4-57-03-00



NARROW THIN PLATE

TITANIUM | STEEL

cortical screws \varnothing 4,5 mm

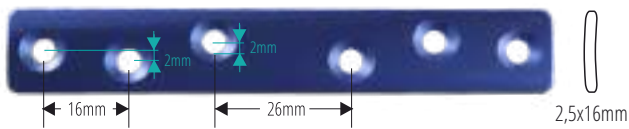

L (mm)	holes	REF No.
71	4	80-X-02-07-04
103	6	80-X-02-07-06
135	8	80-X-02-07-08
167	10	80-X-02-07-10

CORTICAL SCREWS

self-tapping \varnothing 4,5



L (mm)	step	REF
12-80	step 2mm	80-X-01-04-L



DRILL \varnothing 3.2mm 80-4-40-03-32
 DRILL GUIDE 80-4-57-57-00
 SCREWDRIVER S3,5 80-4-57-03-00



AUTOCOMPRESSION SMALL PLATE
TITANIUM | STEEL

cortical screws \varnothing 2,0 mm

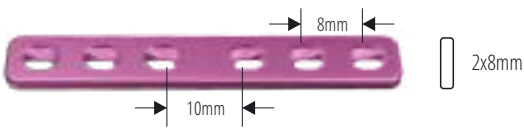

L (mm)	holes	REF No.
36	4	80-X-02-12-04
44	5	80-X-02-12-05
52	6	80-X-02-12-06
60	7	80-X-02-12-07
68	8	80-X-02-12-08
76	9	80-X-02-12-09
84	10	80-X-02-12-10
92	11	80-X-02-12-11
100	12	80-X-02-12-12
116	14	80-X-02-12-14
132	16	80-X-02-12-16
148	18	80-X-02-12-18

CORTICAL SCREWS
self-tapping \varnothing 2,0



L (mm)	REF
6-40 step 2mm	80-X-01-45-L

DRILL \varnothing 1.5mm
DRILL GUIDE 80-4-57-191-00
SCREWDRIVER 80-4-43-33-02.1
HANDLE 80-28-5-1
SHAFT s1,5 80-28-5-2

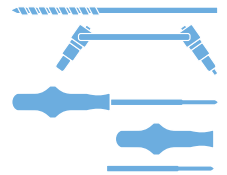

STRAIGHT COMPRESSION PLATE WITH SEPARATE HOLES
TITANIUM | STEEL

cortical screws \varnothing 2,4/2,7 mm

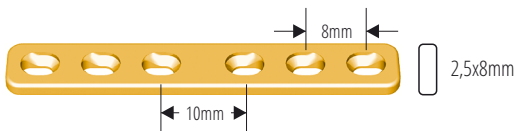

L (mm)	holes	REF No.	L (mm)	holes	REF No.
36	4	80-X-02-11-04	92	11	80-X-02-11-11
44	5	80-X-02-11-05	100	12	80-X-02-11-12
52	6	80-X-02-11-06	108	13	80-X-02-11-13
60	7	80-X-02-11-07	116	14	80-X-02-11-14
68	8	80-X-02-11-08	132	16	80-X-02-11-16
76	9	80-X-02-11-09	148	18	80-X-02-11-18
84	10	80-X-02-11-10			

CORTICAL SCREWS
self-tapping \varnothing 2,4



L (mm)	REF
8-60 step 2mm	80-X-01-239-L

DRILL \varnothing 1.8mm
DRILL GUIDE 80-4-57-183-00
SCREWDRIVER 80-4-57-33-00
HANDLE 80-28-5-1
SHAFT s2,5 80-28-5-3

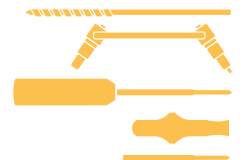

CORTICAL SCREWS
self-tapping \varnothing 2,7



L (mm)	REF
8-60 step 2mm	80-X-01-48-L

DRILL \varnothing 2.0mm
DRILL GUIDE 80-4-57-192-00
SCREWDRIVER 80-4-57-33-00
HANDLE 80-28-5-1
SHAFT s2,5 80-28-5-3

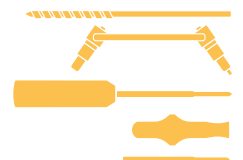

AUTOCOMPRESSION NARROW PLATE, THICK TITANIUM

cortical screws \varnothing 4,5 mm

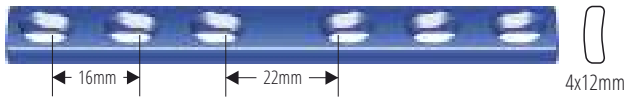

L (mm)	holes	REF No.
71	4	80-1-02-08-04
103	6	80-1-02-08-06
135	8	80-1-02-08-08
167	10	80-1-02-08-10
199	12	80-1-02-08-12
231	14	80-1-02-08-14
263	16	80-1-02-08-16

CORTICAL SCREWS
self-tapping \varnothing 4,5



L (mm)	REF
12-80 step 2mm	80-1-01-04-L

DRILL \varnothing 3.2mm 80-4-40-03-32
DRILL GUIDE 80-4-57-57-00
SCREWDRIVER S3,5 80-4-57-03-00

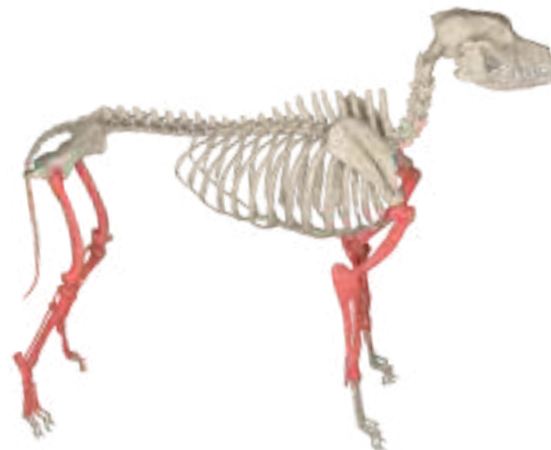

STRAIGHT COMPRESSION PLATE WITH LIMITED CONTACT
TITANIUM | STEEL

cortical screws \varnothing 3,5 mm

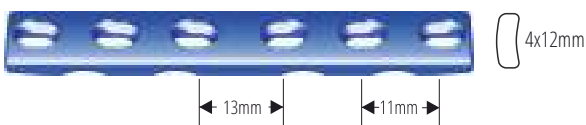

L (mm)	holes	REF No.
77	6	80-X-02-110-06
103	8	80-X-02-110-08
129	10	80-X-02-110-10
155	12	80-X-02-110-12
181	14	80-X-02-110-14
207	16	80-X-02-110-16
233	18	80-X-02-110-18
259	20	80-X-02-110-20

CORTICAL SCREWS
self-tapping \varnothing 3,5



L (mm)	REF
10-70 step 2mm	80-X-01-51-L
70-90 step 5mm	

DRILL \varnothing 2.5mm
DRILL GUIDE 80-4-57-191-00
SCREWDRIVER 80-4-57-33-00
HANDLE 80-28-5-1
SHAFT 80-28-5-3

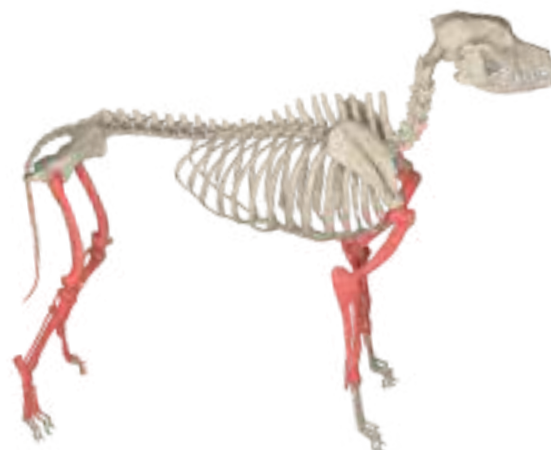
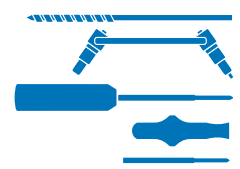

STRAIGHT COMPRESSION PLATE
TITANIUM | STEEL

cortical screws \varnothing 2,0 mm



L (mm)	holes	REF No.	L (mm)	holes	REF No.
17	3	80-X-02-175-03	35	6	80-X-02-175-06
23	4	80-X-02-175-04	71	12	80-X-02-175-12
29	5	80-X-02-175-05			

CORTICAL SCREWS
self-tapping \varnothing 2,0



L (mm)	REF
6-40 step 2mm	80-X-01-45-L

DRILL \varnothing 1.5mm
DRILL GUIDE 80-4-57-191-00
SCREWDRIVER 80-4-43-33-02.1
HANDLE 80-28-5-1
SHAFT s1,5 80-28-5-2

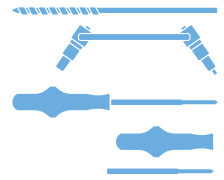

RECONSTRUCTION PLATE, THIN
TITANIUM | STEEL

cortical screws \varnothing 2,0 mm

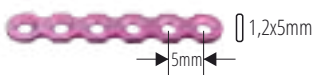

L (mm)	holes	REF. No	L (mm)	holes	REF. No
20	4	80-X-02-55-04	75	15	80-X-02-55-15
30	6	80-X-02-55-06	80	16	80-X-02-55-16
40	8	80-X-02-55-08	90	18	80-X-02-55-18
50	10	80-X-02-55-10	100	20	80-X-02-55-20
60	12	80-X-02-55-12	150	30	80-X-02-55-30
70	14	80-X-02-55-14	200	40	80-X-02-55-40

CORTICAL SCREWS
self-tapping \varnothing 2,0

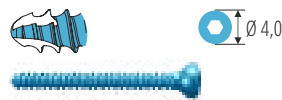

L (mm)	REF
6-40 step 2mm	80-X-01-45-L

DRILL \varnothing 1.5mm
DRILL GUIDE 80-4-57-191-00
SCREWDRIVER 80-4-43-33-02.1
HANDLE 80-28-5-1
SHAFT s1,5 80-28-5-2

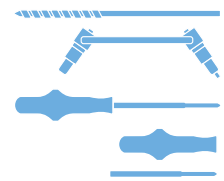

STRAIGHT RECONSTRUCTION PLATE
TITANIUM | STEEL

cortical screws \varnothing 2,7 mm

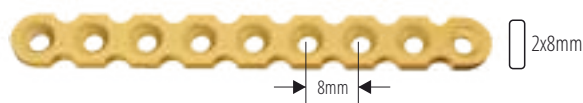

L (mm)	holes	REF No.	L (mm)	holes	REF No.
48	6	80-X-02-54-06	112	14	80-X-02-54-14
64	8	80-X-02-54-08	128	16	80-X-02-54-16
80	10	80-X-02-54-10	144	18	80-X-02-54-18
96	12	80-X-02-54-12	160	20	80-X-02-54-20

CORTICAL SCREWS
self-tapping \varnothing 2,4



L (mm)	REF
8-60 step 2mm	80-X-01-239-L

DRILL \varnothing 1.8mm
DRILL GUIDE 80-4-57-183-00
SCREWDRIVER 80-4-57-33-00
HANDLE 80-28-5-1
SHAFT s2,5 80-28-5-3



CORTICAL SCREWS
self-tapping \varnothing 2,7



L (mm)	REF
8-60 step 2mm	80-X-01-48-L

DRILL \varnothing 2.0mm
DRILL GUIDE 80-4-57-192-00
SCREWDRIVER 80-4-57-33-00
HANDLE 80-28-5-1
SHAFT s2,5 80-28-5-3

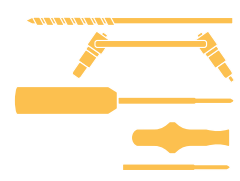
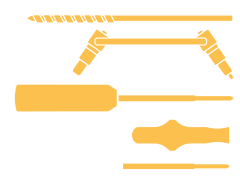

STRAIGHT RECONSTRUCTION PLATE
TITANIUM | STEEL

cortical screws \varnothing 3,5/4,0 mm



L (mm)	holes	REF No.	L (mm)	holes	REF No.
72	6	80-X-02-49-06	168	14	80-X-02-49-14
84	7	80-X-02-49-07	192	16	80-X-02-49-16
96	8	80-X-02-49-08	216	18	80-X-02-49-18
108	9	80-X-02-49-09	240	20	80-X-02-49-20
120	10	80-X-02-49-10	264	22	80-X-02-49-22
144	12	80-X-02-49-12	288	24	80-X-02-49-24



CORTICAL SCREWS
self-tapping \varnothing 3,5



L (mm)	step	REF
10-70	step 2mm	80-X-01-51-L
70-90	step 5mm	80-X-01-51-L

CANCELLOUS SCREWS
self-tapping \varnothing 4,0

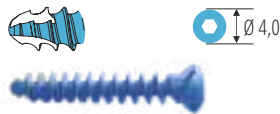

L (mm)	step	REF
10-50	step 2mm	80-X-01-321-L
50-75	step 5mm	80-X-01-321-L

DRILL \varnothing 2.5mm
DRILL GUIDE 80-4-57-191-00
SCREWDRIVER 80-4-57-33-00
HANDLE 80-28-5-1
SHAFT 80-28-5-3

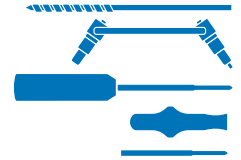

DRILL \varnothing 2.0mm
DRILL GUIDE 80-4-57-192-00
SCREWDRIVER 80-4-57-33-00
HANDLE 80-28-5-1
SHAFT s2,5 80-28-5-3

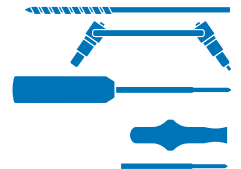

RECONSTRUCTION CURVE PLATE
TITANIUM

cortical screws \varnothing 3,5/4,0 mm

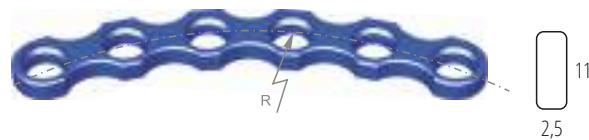

L (mm)	R (mm)	holes	REF No.
57	80	4	80-1-02-46-04
86	80	6	80-1-02-46-06
111	80	8	80-1-02-46-08
132	80	10	80-1-02-46-10
58	100	4	80-1-02-47-04
88	100	6	80-1-02-47-06
115	100	8	80-1-02-47-08
139	100	10	80-1-02-47-10

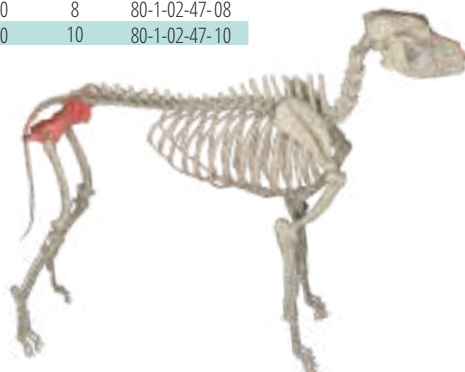

CORTICAL SCREWS
self-tapping \varnothing 3,5



L (mm)	step	REF
10-70	step 2mm	80-1-01-51-L
70-90	step 5mm	80-1-01-51-L

CANCELLOUS SCREWS
self-tapping \varnothing 4,0

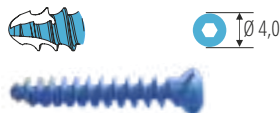

L (mm)	step	REF
10-50	step 2mm	80-1-01-321-L
50-75	step 5mm	80-1-01-321-L

DRILL \varnothing 2.5mm
DRILL GUIDE 80-4-57-191-00
SCREWDRIVER 80-4-57-33-00
HANDLE 80-28-5-1
TRZPIEŃ 80-28-5-3

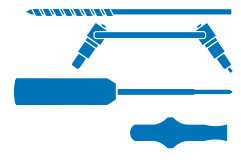

DRILL \varnothing 2.0mm
DRILL GUIDE 80-4-57-192-00
SCREWDRIVER 80-4-57-33-00
HANDLE 80-28-5-1
SHAFT s2,5 80-28-5-3

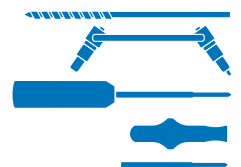
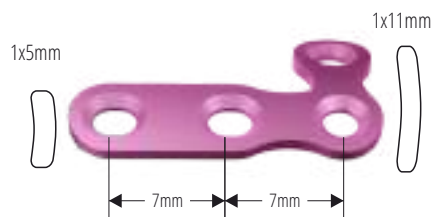

PLATE -L- 90° mini
TITANIUM | STEEL

cortical screws \varnothing 2,0mm



L (mm)	holes	LEFT	RIGHT
19	2	80-X-04-32-01	80-X-04-32-02
26	3	80-X-04-32-05	80-X-04-32-06
33	4	80-X-04-32-07	80-X-04-32-08
40	5	80-X-04-32-09	80-X-04-32-10



CORTICAL SCREWS
self-tapping \varnothing 2,0

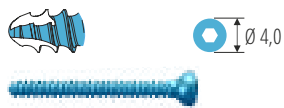

L (mm)	REF
6-40 step 2mm	80-X-01-45-L

DRILL \varnothing 1.5mm
DRILL GUIDE 80-4-57-191-00
SCREWDRIVER 80-4-43-33-02.1
HANDLE 80-28-5-1
SHAFT \leq 1,5 80-28-5-2

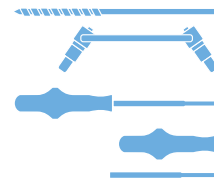
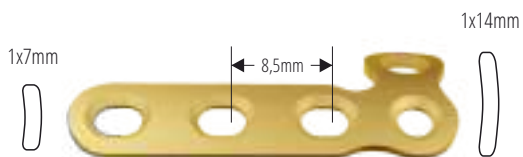
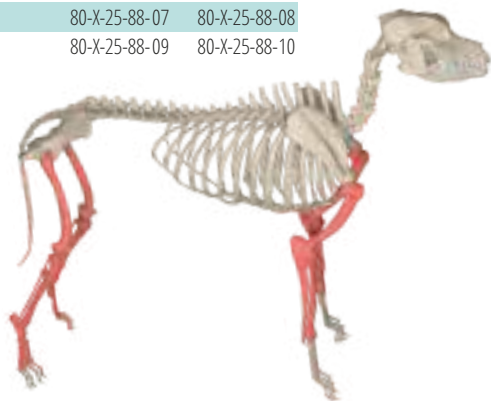

PLATE -L- 90°
TITANIUM | STEEL

cortical screws \varnothing 2,7mm



L (mm)	holes	LEFT	RIGHT
23,5	2	80-X-25-88-01	80-X-25-88-02
32	3	80-X-25-88-03	80-X-25-88-04
40,5	4	80-X-25-88-05	80-X-25-88-06
49	5	80-X-25-88-07	80-X-25-88-08
57,5	6	80-X-25-88-09	80-X-25-88-10



CORTICAL SCREWS
self-tapping \varnothing 2,7



L (mm)	REF
8-60 step 2mm	80-X-01-48-L

DRILL \varnothing 2.0mm
DRILL GUIDE 80-4-57-192-00
SCREWDRIVER 80-4-57-33-00
HANDLE 80-28-5-1
SHAFT \leq 2,5 80-28-5-3

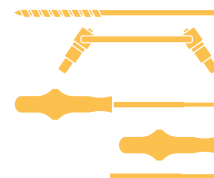
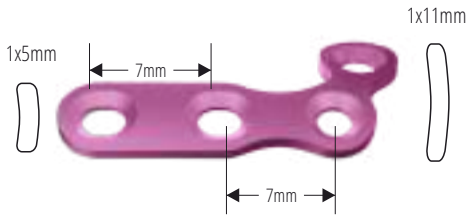
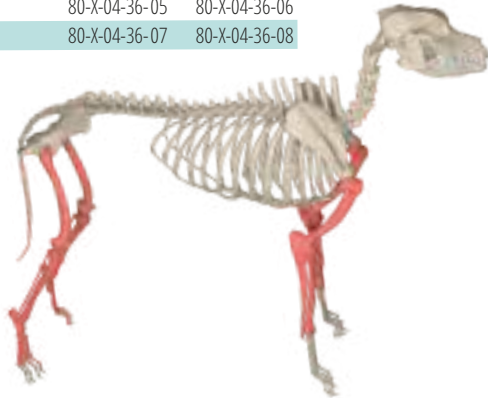

PLATE -L- 110° mini
TITANIUM | STEEL

cortical screws \varnothing 2,0mm



L (mm)	holes	LEFT	RIGHT
21,2	2	80-X-04-36-01	80-X-04-36-02
28,2	3	80-X-04-36-03	80-X-04-36-04
35,2	4	80-X-04-36-05	80-X-04-36-06
42,2	5	80-X-04-36-07	80-X-04-36-08



CORTICAL SCREWS
self-tpping \varnothing 2,0



L (mm)	REF
6-40 step 2mm	80-X-01-45-L

DRILL \varnothing 1.5mm
DRILL GUIDE 80-4-57-191-00
SCREWDRIVER 80-4-43-33-02.1
HANDLE 80-28-5-1
SHAFT \leq 1,5 80-28-5-2

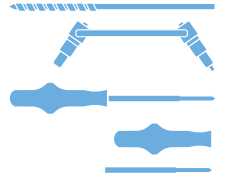
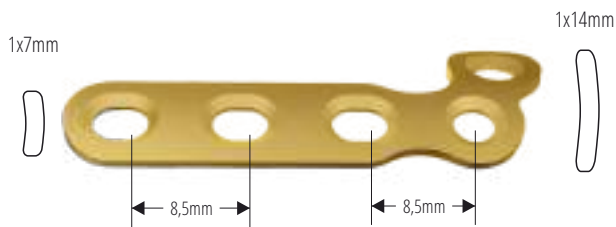

PLATE -L- 110°
TITANIUM | STEEL

cortical screws \varnothing 2,7mm



L (mm)	holes	LEFT	RIGHT
35	3	80-X-04-34-01	80-X-04-34-02
43,5	4	80-X-04-34-03	80-X-04-34-04
52	5	80-X-04-34-05	80-X-04-34-06
60,5	6	80-X-04-34-07	80-X-04-34-08



CORTICAL SCREWS
self-tapping \varnothing 2,7



L (mm)	REF
8-60 step 2mm	80-X-01-48-L

DRILL \varnothing 2.0mm
DRILL GUIDE 80-4-57-192-00
SCREWDRIVER 80-4-57-33-00
HANDLE 80-28-5-1
SHAFT \leq 2,5 80-28-5-3

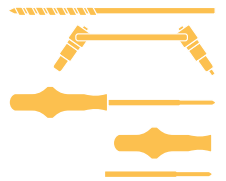
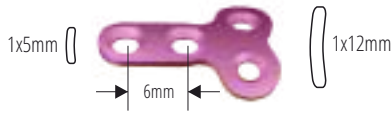

PLATE -T- mini
TITANIUM | STEEL

cortical screws \varnothing 2,0mm



L (mm)	holes	REF No.
18	2	80-X-04-26-19
24	3	80-X-04-26-21
30	4	80-X-04-26-23
36	5	80-X-04-26-25
42	6	80-X-04-26-27



CORTICAL SCREWS
self-tapping \varnothing 2,0



L (mm)	REF
6-40 step 2mm	80-X-01-45-L

DRILL \varnothing 1.5mm
DRILL GUIDE 80-4-57-191-00
SCREWDRIVER 80-4-43-33-02.1
HANDLE 80-28-5-1
SHAFT \leq 1,5 80-28-5-2

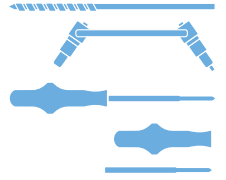
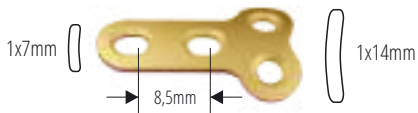

PLATE -T
TITANIUM | STEEL

cortical screws \varnothing 2,7mm



L (mm)	holes	REF No.
23,5	2	80-X-04-25-30
32	3	80-X-04-25-32
40,5	4	80-X-04-25-34
49	5	80-X-04-25-36
57,5	6	80-X-04-25-38



CORTICAL SCREWS
self-tapping \varnothing 2,7



L (mm)	REF
8-60 step 2mm	80-X-01-48-L

WIERTŁO \varnothing 2.0mm
PROWADNIK WIERTŁA 80-4-57-192-00
WKRĘTAK 80-4-57-33-00
RĘKOJEŚĆ 80-28-5-1
TRZPIEŃ \leq 2,5 80-28-5-3

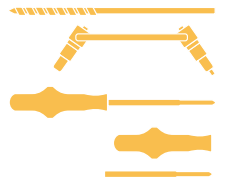

TUBULAR PLATE 1/3 TITANIUM|STEEL

cortical screws \varnothing 2,4/2,7mm



L (mm)	holes	REF No.
31	4	80-X-02-27-04
47	6	80-X-02-27-06
63	8	80-X-02-27-08
79	10	80-X-02-27-10
95	12	80-X-02-27-12



CORTICAL SCREWS self-tapping \varnothing 2,4



L (mm)	REF
8-60 step 2mm	80-X-01-239-L

CORTICAL SCREWS self-tapping \varnothing 2,7

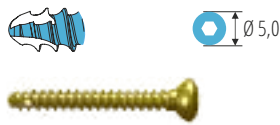

L (mm)	REF
8-60 step 2mm	80-X-01-

DRILL \varnothing 1.8mm
DRILL GUIDE 80-4-57-183-00
SCREWDRIVER 80-4-57-33-00
HANDLE 80-28-5-1
SHAFT s2,5 80-28-5-3

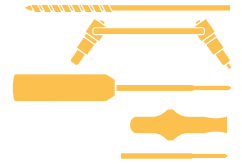

DRILL \varnothing 2.0mm
DRILL GUIDE 80-4-57-192-00
SCREWDRIVER 80-4-57-33-00
HANDLE 80-28-5-1
SHAFT s2,5 80-28-5-3

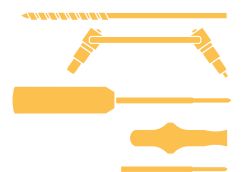

TUBULAR PLATE 1/3 TITANIUM|STEEL

cortical screws \varnothing 3,5mm

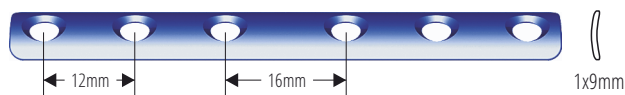

L (mm)	holes	REF No.
49	4	80-X-02-25-04
73	6	80-X-02-25-06
97	8	80-X-02-25-08
121	10	80-X-02-25-10
145	12	80-X-02-25-12



CORTICAL SCREWS self-tapping \varnothing 3,5

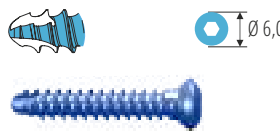

L (mm)	REF
10-70 step 2mm	80-X-01-51-L
70-90 step 5mm	

DRILL \varnothing 2.5mm
DRILL GUIDE 80-4-57-191-00
SCREWDRIVER 80-4-57-33-00
HANDLE 80-28-5-1
SHAFT 80-28-5-3

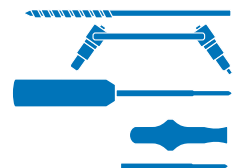

TUBULAR PLATE 1/3
TITANIUM | STEEL

cortical screws \varnothing 4,5mm

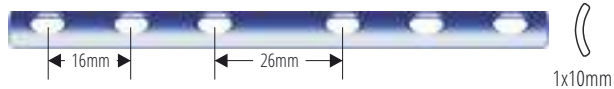

L (mm)	holes	REF No.
71	4	80-X-02-24-04
103	6	80-X-02-24-06
135	8	80-X-02-24-08
167	10	80-X-02-24-10

CORTICAL SCREWS
self-tapping \varnothing 4,5



L (mm)	REF
12-80 step 2mm	80-X-01-04-L

DRILL \varnothing 3.2mm
DRILL GUIDE 80-4-57-57-00
SCREWDRIVER 80-4-57-03-00



TUBULAR PLATE 1/2
TITANIUM | STEEL

cortical screws \varnothing 4,5mm

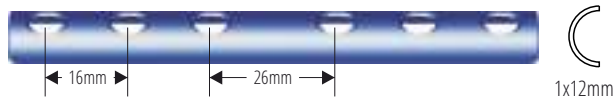

L (mm)	holes	REF No.
71	4	80-X-02-23-04
103	6	80-X-02-23-06
135	8	80-X-02-23-08
167	10	80-X-02-23-10

CORTICAL SCREWS
self-tapping \varnothing 4,5



L (mm)	REF
12-80 step 2mm	80-X-01-

DRILL \varnothing 3.2mm
DRILL GUIDE 80-4-57-57-00
SCREWDRIVER 80-4-57-03-00



LOCKING COMPRESSION TPLO PLATE TITANIUM

cortical screws \varnothing 2,4/2,7 mm

locking screws \varnothing 2,4/2,7 mm

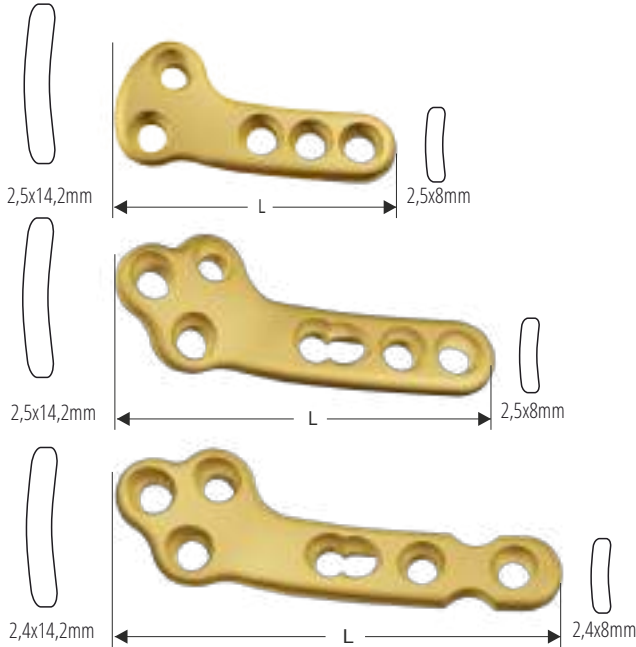

L (mm)	holes	LEFT	RIGHT
31,5	5	80-1-25-32-05	80-1-25-33-05
38	6	80-1-25-32-06/1	80-1-25-33-06/1
46	6	80-1-25-32-06	80-1-25-33-06



CORTICAL SCREWS

self-tapping \varnothing 2,4



L (mm)	REF
8-60 step 2mm	80-1-01-239-L

LOCKING SCREWS

self-tapping \varnothing 2,4



L (mm)	REF
8-40 step 2mm	80-1-01-200-L

LOCKING SCREWS

multi-angle \varnothing 2,4



L (mm)	T8
8-40 step 2mm	80-1-01-298-L

CORTICAL SCREWS

self-tapping \varnothing 2,7



L (mm)	REF
8-60 step 2mm	80-1-01-48-L

LOCKING SCREWS

self-tapping \varnothing 2,7



L (mm)	REF
8-40 step 2mm	80-1-01-201-L

LOCKING SCREWS

multi-angle \varnothing 2,7



L (mm)	REF
10-40 step 2mm	80-1-01-325-L

DRILL \varnothing 1.8mm
DRILL GUIDE 80-4-57-183-00
SCREWDRIVER 80-4-57-33-00
HANDLE 80-28-5-1
SHAFT s2,5 80-28-5-3

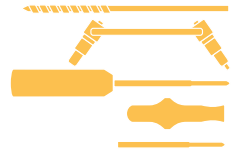

DRILL \varnothing 1.8mm
DRILL GUIDE 80-4-57-49-00
SCREWDRIVER 80-4-57-33-00
HANDLE 80-28-5-1
SHAFT s2,5 80-28-5-3



DRILL \varnothing 1.8mm
VARIABLE ANGLE SLEEVE 80-4-57-171-01
SCREWDRIVER T8 80-4-57-76-00
HANDLE 80-28-5-1
SHAFT T8 80-4-43-45-16.1



DRILL \varnothing 2.0mm
DRILL GUIDE 80-4-57-192-00
SCREWDRIVER 80-4-57-33-00
HANDLE 80-28-5-1
SHAFT s2,5 80-28-5-3

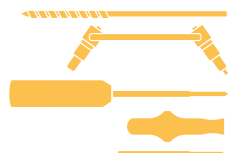

DRILL \varnothing 2.0mm
DRILL GUIDE 80-4-57-74-00
SCREWDRIVER 80-4-57-33-00
HANDLE 80-28-5-1
SHAFT s2,5 80-28-5-3



DRILL \varnothing 2.0mm
VARIABLE ANGLE SLEEVE 80-4-57-171-02
SCREWDRIVER T8 4-57-76-00
HANDLE 80-28-5-1
SHAFT 80-4-43-45-16.1



**LOCKING COMPRESSION TPLO PLATE
TITANIUM**

cortical screws \varnothing 3,5 mm

locking screws \varnothing 3,5 mm

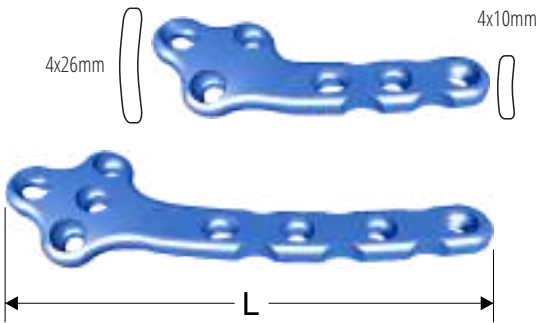

L (mm)	holes	LEFT	RIGHT
60	6	80-1-25-30-06/1	80-1-25-31-06/1
72	6	80-1-25-30-06	80-1-25-31-06
88	8	80-1-25-30-08	80-1-25-31-08



**CORTICAL SCREWS
self-tapping \varnothing 3,5**

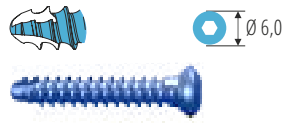

L (mm)	REF
10-70 step 2mm	
70-90 step 5mm	80-1-01-51-L

**LOCKING SCREWS
self-tapping \varnothing 3,5**

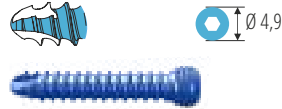

L (mm)	REF
10-60 step 2mm	
70-95 step 5mm	80-1-01-11-L

**LOCKING SCREWS
multi-angle \varnothing 3,5**



L (mm)	REF
10-60 step 2mm	
60-95 step 5mm	80-1-01-322-L

DRILL \varnothing 2.5mm
DRILL GUIDE 80-4-57-191-00
SCREWDRIVER 80-4-57-33-00
HANDLE 80-28-5-1
SHAFT 80-28-5-3

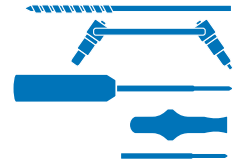

DRILL \varnothing 2.7mm
HOLDING SLEEVE 80-4-57-51-00
SCREWDRIVER 80-4-57-33-00
HANDLE 80-28-5-1
SHAFT s2,5 80-28-5-3



DRILL \varnothing 2.7mm
VARIABLE ANGLE SLEEVE 80-4-57-171-03
SCREWDRIVER T15 80-4-57-181-00
HANDLE 80-28-5-1
SHAFT T15 80-4-43-45-22.1

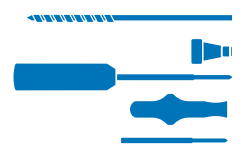

**COMPRESSION STRAIGHT TPLO PLATE
TITANIUM | STEEL**

cortical screws \varnothing 2,4/2,7 mm

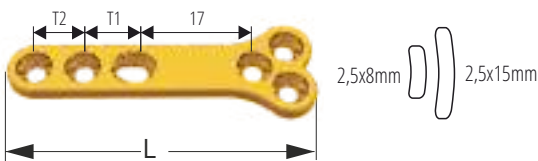

L (mm)	t1	t2	holes	REF No.
45	8	7	6	80-X-25-93-01
52	11	11	6	80-X-25-93-02

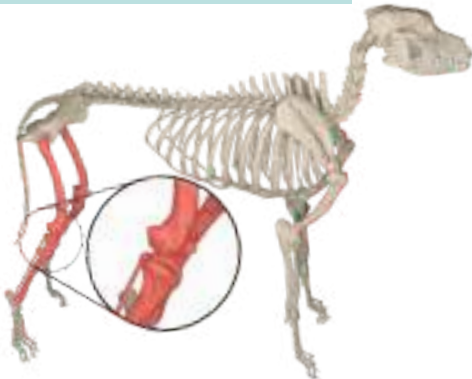

**CORTICAL SCREWS
self-tapping \varnothing 2,4**



L (mm)	REF
8-60 step 2mm	80-X-01-239-L

**CORTICAL SCREWS
self-tapping \varnothing 2,7**



L (mm)	REF
8-60 step 2mm	80-X-01-48-L

DRILL \varnothing 1.8mm
DRILL GUIDE 80-4-57-183-00
SCREWDRIVER 80-4-57-33-00
HANDLE 80-28-5-1
SHAFT s2,5 80-28-5-3

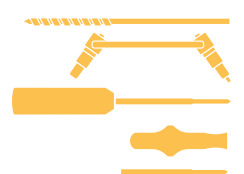

DRILL \varnothing 2.0mm
DRILL GUIDE 80-4-57-192-00
SCREWDRIVER 80-4-57-33-00
HANDLE 80-28-5-1
SHAFT s2,5 80-28-5-3

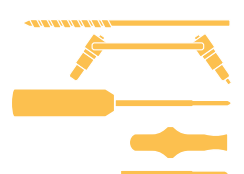

COMPRESSION STRAIGHT TPLO PLATE
TITANIUM|STEEL

cortical screws \varnothing 3,5 mm

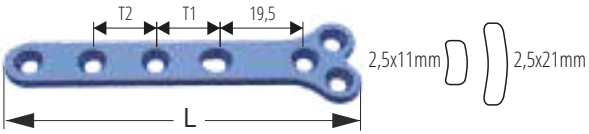

L (mm)	t1	t2	holes	REF No.
55	10	8	6	80-X-25-94-01
63	14	12	6	80-X-25-94-02
71	12	11	7	80-X-25-94-03
79	14	14	7	80-X-25-94-04

CORTICAL SCREWS
self-tapping \varnothing 3,5

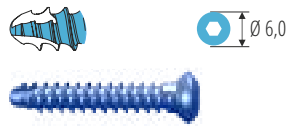

L (mm)	REF
10-70 step 2mm	
70-90 step 5mm	80-X-01-51-L

DRILL \varnothing 2.5mm
DRILL GUIDE 80-4-57-191-00
SCREWDRIVER 80-4-57-33-00
HANDLE 80-28-5-1
SHAFT 80-28-5-3

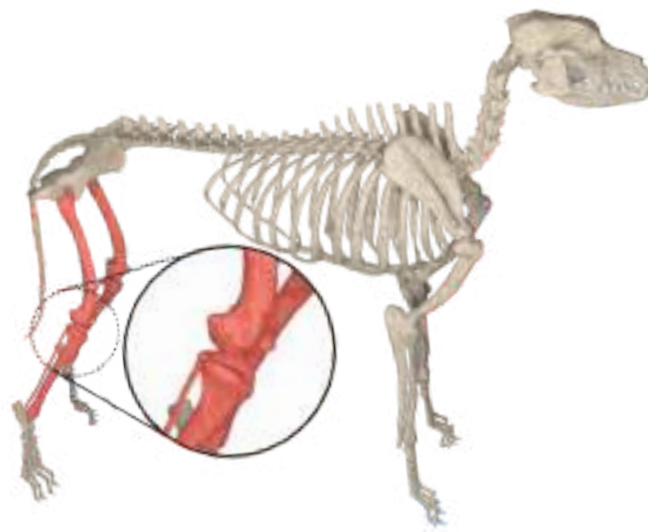
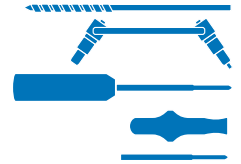

**PLATE FOR DOUBLE / TRIPLE
PELVIS OSTEOTOMIES -DPO/TPO
TITANIUM**

cortical screws \varnothing 3,5mm

locking screws \varnothing 3,5mm

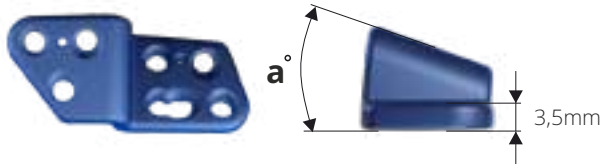

a°	LEFT	RIGHT
20°	80-1-25-100-20	80-1-25-101-20
25°	80-1-25-100-25	80-1-25-101-25
30°	80-1-25-100-30	80-1-25-101-30
35°	80-1-25-100-35	80-1-25-101-35

CORTICAL SCREWS

self-tapping \varnothing 3,5



L (mm)	REF
10-70 step 2mm	
70-90 step 5mm	80-1-01-51-L

LOCKING SCREWS

self-tapping \varnothing 3,5



L (mm)	REF
10-60 step 2mm	
70-95 step 5mm	80-1-01-11-L

LOCKING SCREWS

multi-angle \varnothing 3,5



L (mm)	REF
10-60 step 2mm	
60-95 step 5mm	80-1-01-322-L



DRILL \varnothing 2.5mm
DRILL GUIDE 80-4-57-191-00
SCREWDRIVER 80-4-57-33-00
HANDLE 80-28-5-1
SHAFT 80-28-5-3

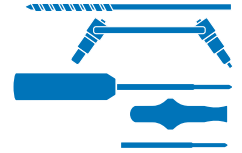

DRILL \varnothing 2.7mm
HOLDING SLEEVE 80-4-57-51-00
SCREWDRIVER 80-4-57-33-00
HANDLE 80-28-5-1
SHAFT s2,5 80-28-5-3



DRILL \varnothing 2.7mm
VARIABLE ANGLE SLEEVE 80-4-57-171-03
SCREWDRIVER T15 80-4-57-181-00
HANDLE 80-28-5-1
SHAFT T15 80-4-43-45-22.1

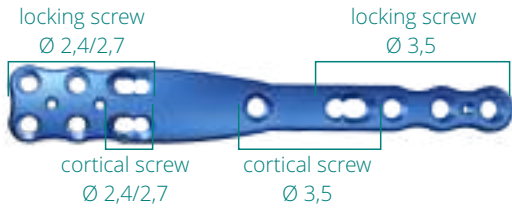

PLATE MANIPULATOR
80-28-8-4.35



PANCARPAL ARTHRODESIS PLATE WITH LIMITED CONTACT 2.4/2.7; 3,5 TITANIUM

cortical and locking screws \varnothing 2,4/2,7 mm
cortical and locking screws \varnothing 3,5 mm



L (mm)	holes	REF No.
96,4	3	80-1-25-42-03
104,1	4	80-1-25-42-04
113,6	5	80-1-25-42-05
123,1	6	80-1-25-42-06
132,6	7	80-1-25-42-07

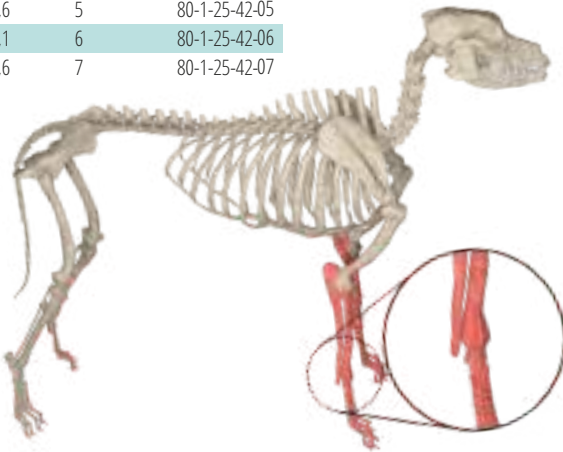

CORTICAL SCREWS self-tapping \varnothing 2,4



L (mm)	REF
8-60 step 2mm	80-1-01-239-L

LOCKING SCREWS self-tapping \varnothing 2,4



L (mm)	REF
8-40 step 2mm	80-1-01-200-L

CORTICAL SCREWS multi-angle \varnothing 2,4



L (mm)	REF
8-40 step 2mm	80-1-01-298-L

CORTICAL SCREWS self-tapping \varnothing 2,7



L (mm)	REF
8-60 step 2mm	80-1-01-48-L

DRILL \varnothing 1.8mm
DRILL GUIDE 80-4-57-183-00
SCREWDRIVER 80-4-57-33-00
HANDLE 80-28-5-1
SHAFT s2,5 80-28-5-3

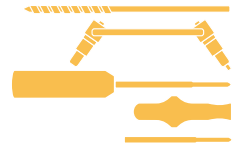

DRILL \varnothing 1.8mm
HOLDING SLEEVE 80-4-57-49-00
SCREWDRIVER 80-4-57-33-00
HANDLE 80-28-5-1
SHAFT s2,5 80-28-5-3



DRILL \varnothing 1.8mm
VARIABLE ANGLE SLEEVE 80-4-57-171-01
SCREWDRIVER T8 80-4-57-76-00
HANDLE 80-28-5-1
SHAFT T8 80-4-43-45-16.1



DRILL \varnothing 2.0mm
HOLDING SLEEVE 80-4-57-192-00
SCREWDRIVER 80-4-57-33-00
HANDLE 80-28-5-1
SHAFT s2,5 80-28-5-3

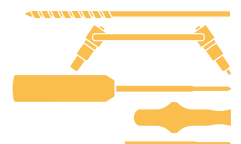

LOCKING SCREWS self-tapping \varnothing 2,7



L (mm)	REF
8-40 step 2mm	80-1-01-201-L

LOCKING SCREWS multi-angle \varnothing 2,7



L (mm)	REF
10-40 step 2mm	80-1-01-325-L

CORTICAL SCREWS self-tapping \varnothing 3,5



L (mm)	REF
10-70 step 2mm	80-1-01-51-L
70-90 step 5mm	

LOCKING SCREWS multi-angle \varnothing 3,5



L (mm)	REF
10-60 step 2mm	80-1-01-322-L
60-95 step 5mm	

LOCKING SCREWS self-tapping \varnothing 3,5



L (mm)	REF
10-60 step 2mm	80-1-01-11-L
70-95 step 5mm	

DRILL \varnothing 2.0mm
HOLDING SLEEVE 80-4-57-74-00
SCREWDRIVER 80-4-57-33-00
HANDLE 80-28-5-1
SHAFT s2,5 80-28-5-3



DRILL \varnothing 2.0mm
KEY SLEEVE 80-4-57-171-00
VARIABLE ANGLE SLEEVE 80-4-57-171-02
SCREWDRIVER T8 80-4-57-76-00
HANDLE 80-28-5-1
SHAFT 80-4-43-45-16.1



DRILL \varnothing 2.5mm
DRILL GUIDE 80-4-57-191-00
SCREWDRIVER 80-4-57-33-00
HANDLE 80-28-5-1
SHAFT 80-28-5-3

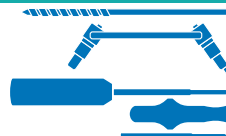

DRILL \varnothing 2.7mm
VARIABLE ANGLE SLEEVE 80-4-57-17-03
SCREWDRIVER T15 80-4-57-181-00
HANDLE 80-28-5-1
SHAFT T15 80-4-43-45-22.1

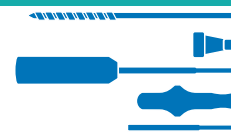

DRILL \varnothing 2.7mm
HOLDING SLEEVE 80-4-57-51-00
SCREWDRIVER 80-4-57-33-00
HANDLE 80-28-5-1
SHAFT s2,5 80-28-5-3



PANCARPAL ARTHRODESIS PLATE WITH LIMITED CONTACT 2.0; 2.4/2.7 TITANIUM

locking and cortical screws \varnothing 2,0 mm

locking and cortical screws \varnothing 2,4/2,7 mm

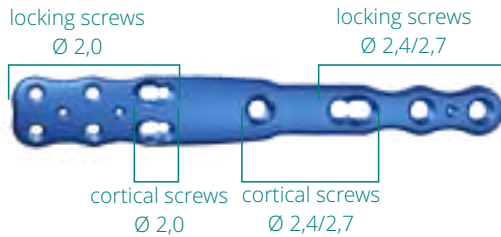

L (mm)	holes	REF No.
77	2	80-1-25-44-02
90	3	80-1-25-44-03
97	4	80-1-25-44-04

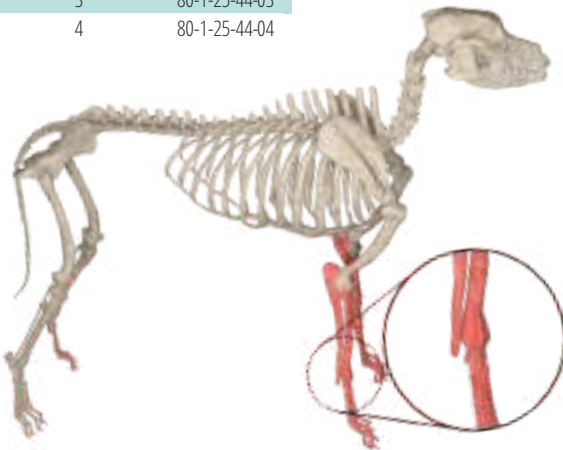

CORTICAL SCREWS self-tapping \varnothing 2,0

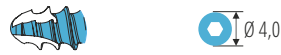

L (mm)	REF
6-40 step 2mm	80-1-01-45-L

LOCKING SCREWS self-tapping \varnothing 2,0



L (mm)	REF
6-40 step 2mm	80-1-01-260-L

CORTICAL SCREWS self-tapping \varnothing 2,4



L (mm)	REF
8-60 step 2mm	80-1-01-239-L

LOCKING SCREWS self-tapping \varnothing 2,4



L (mm)	REF
8-40 step 2mm	80-1-01-200-L

DRILL \varnothing 1.5mm
DRILL GUIDE 80-4-57-191-00
SCREWDRIVER 80-4-43-33-02.1
HANDLE 80-28-5-1
SHAFT s1,5 80-28-5-2

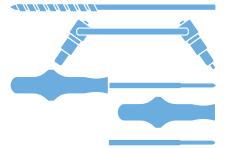

DRILL \varnothing 1.5mm
HOLDING SLEEVE 80-4-57-122-00
SCREWDRIVER 80-4-43-33-02.1



DRILL \varnothing 1.8mm
DRILL GUIDE 80-4-57-183-00
SCREWDRIVER 80-4-57-33-00
HANDLE 80-28-5-1
SHAFT s2,5 80-28-5-3

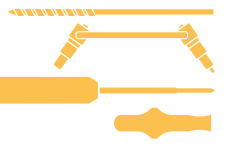

DRILL \varnothing 1.8mm
HOLDING SLEEVE 80-4-57-49-00
SCREWDRIVER 80-4-57-33-00
HANDLE 80-28-5-1
SHAFT s2,5 80-28-5-3



LOCKING SCREWS multi-angle \varnothing 2,4



L (mm)	T8	REF
8-40 step 2mm		80-1-01-298-L

DRILL \varnothing 1.8mm
SLEEVE KEY 80-4-57-171-00
VARIABLE ANGLE SLEEVE 80-4-57-171-01
SCREWDRIVER T8 80-4-57-76-00
HANDLE 80-28-5-1
SHAFT T8 80-4-43-45-16.1

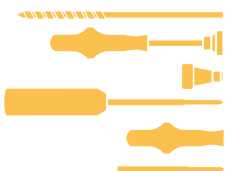

CORTICAL SCREWS self-tapping \varnothing 2,7



L (mm)	REF
8-60 step 2mm	80-1-01-48-L

DRILL \varnothing 2.0mm
DRILL GUIDE 80-4-57-192-00
SCREWDRIVER 80-4-57-33-00
HANDLE 80-28-5-1
SHAFT s2,5 80-28-5-3

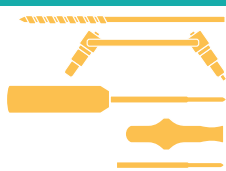

LOCKING SCREWS self-tapping \varnothing 2,7



L (mm)	REF
8-40 step 2mm	80-1-01-201-L

DRILL \varnothing 2.0mm
HOLDING SLEEVE 80-4-57-74-00
SCREWDRIVER 80-4-57-33-00
HANDLE 80-28-5-1
SHAFT s2,5 80-28-5-3

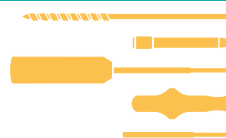

LOCKING SCREWS multi-angle \varnothing 2,7



L (mm)	REF
10-40 step 2mm	80-1-01-325-L

DRILL \varnothing 2.0mm
SLEEVE KEY 80-4-57-171-00
VARIABLE ANGLE SLEEVE 80-4-57-171-02
SCREWDRIVER T8 80-4-57-76-00
HANDLE 80-28-5-1
SHAFT 80-4-43-45-16.1

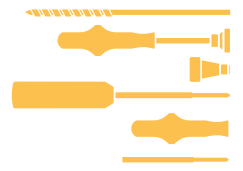

LOCKING COMPRESSION PANTARSAL ARTHRODESIS PLATES

TITANIUM

cortical and locking screws \varnothing 2,0 mm

cortical and locking screws \varnothing 2,4 / 2,7 mm

cortical and locking screws \varnothing 3,5 mm

L (mm)	T1 (mm)	T2 (mm)	T3 (mm)	T4 (mm)	THICKNESS	LEFT	RIGHT
73,3	6	37	24	7	2	80-1-25-213-01	80-1-25-214-01
96,4	8	47	27	8	2	80-1-25-213-02	80-1-25-214-02
127,4	9	60	32	10,5	2,5	80-1-25-213-03	80-1-25-214-03
127,4	9	60	32	10,5	2,5	80-1-25-213-04	80-1-25-214-04
144,5	10	68	36	12	3	80-1-25-213-05	80-1-25-214-05

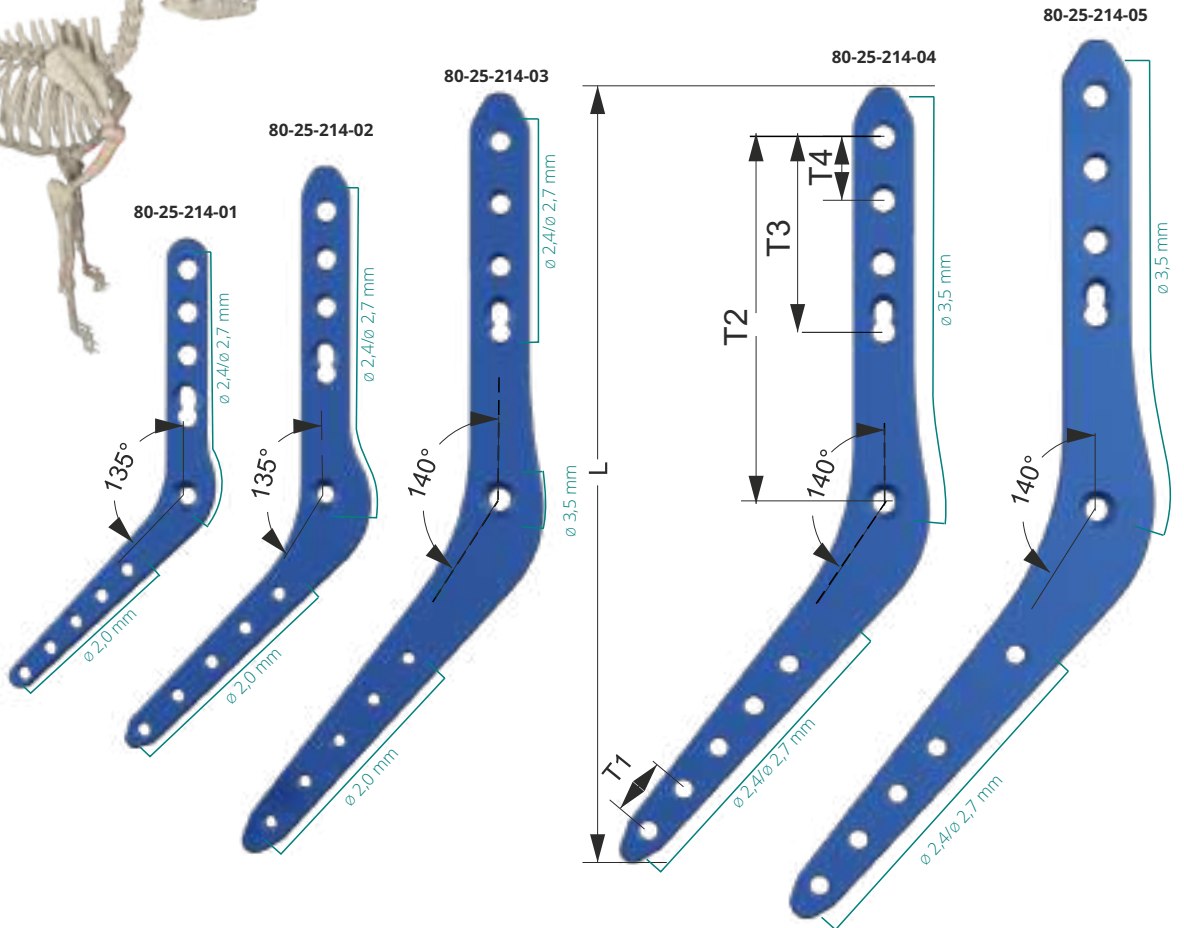

LOCKING SCREWS self-tapping

\varnothing 2,0



L (mm)	REF
8-30 step 2mm	80-1-01-260-L

DRILL \varnothing 1.5mm
HOLDING SLEEVE
80-4-57-122-00
SCREWDRIVER
80-4-43-33-02.1

CORTICAL SCREWS self-tapping

\varnothing 2,4



L (mm)	REF
8-60 step 2mm	80-1-01-239-L

LOCKING SCREWS self-tapping

\varnothing 2,4



L (mm)	REF
8-40 step 2mm	80-1-01-200-L

CORTICAL SCREWS self-tapping

\varnothing 2,7



L (mm)	REF
8-60 step 2mm	80-1-01-48-L

LOCKING SCREWS self-tapping

\varnothing 2,7



L (mm)	REF
8-40 step 2mm	80-1-01-201-L

CORTICAL SCREWS self-tapping

\varnothing 3,5



L (mm)	REF
10-70 step 2mm	
70-90 step 5mm	80-1-01-51-L

LOCKING SCREWS self-tapping

\varnothing 3,5



L (mm)	REF
10-60 step 2mm	
70-95 step 5mm	80-1-01-11-L

DRILL \varnothing 1.8mm
DRILL GUIDE
80-4-57-183-00
SCREWDRIVER
80-4-57-33-00
HANDLE 80-28-5-1
SHAFT s2,5 80-28-5-3

DRILL \varnothing 1.8mm
HOLDING SLEEVE
80-4-57-49-00
SCREWDRIVER
80-4-57-33-00
HANDLE 80-28-5-1
SHAFT s2,5 80-28-5-3

DRILL \varnothing 2.0mm
DRILL GUIDE
80-4-57-192-00
SCREWDRIVER
80-4-57-33-00
HANDLE 80-28-5-1
SHAFT s2,5 80-28-5-3

DRILL \varnothing 2.0mm
HOLDING SLEEVE
80-4-57-74-00
SCREWDRIVER
80-4-57-33-00
HANDLE 80-28-5-1
SHAFT s2,5 80-28-5-3

DRILL \varnothing 2.5mm
DRILL GUIDE
80-4-57-191-00
SCREWDRIVER
80-4-57-33-00
HANDLE 80-28-5-1
SHAFT 80-28-5-3

DRILL \varnothing 2.7mm
HOLDING SLEEVE
80-4-57-51-00
SCREWDRIVER
80-4-57-33-00
HANDLE 80-28-5-1
SHAFT s2,5 80-28-5-3

COMPRESSION PANTARSAL ARTHRODESIS PLATES TITANIUM

cortical screw \varnothing 2,0 mm

cortical screw \varnothing 2,4 / 2,7 mm

cortical screw \varnothing 3,5 mm



L (mm)	L1 (mm)	T1 (mm)	T2 (mm)	T3 (mm)	THICKNESS	LEFT	RIGHT
73	37	6	28	7	2	80-1-25-209-01	80-1-25-210-01
96	47	8	35,3	8	2	80-1-25-209-02	80-1-25-210-02
127,5	60	9	43,5	10,5	2,5	80-1-25-209-03	80-1-25-210-03
127,5	60	9	42,5	10,5	2,5	80-1-25-209-04	80-1-25-210-04
144,5	68	10	49,5	12	3	80-1-25-209-05	80-1-25-210-05

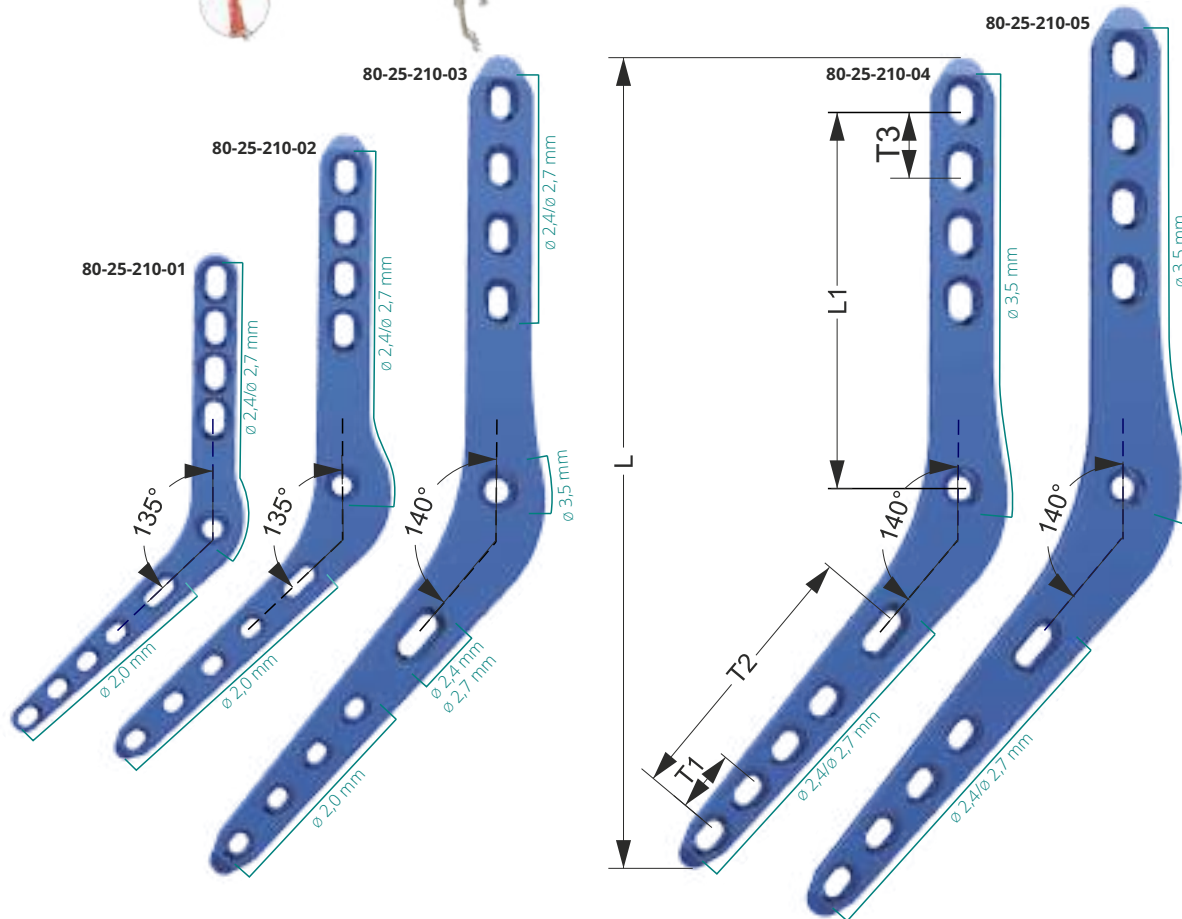

CORTICAL SCREWS self-tapping \varnothing 2,0

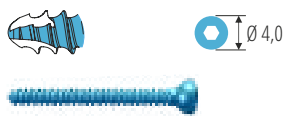

L (mm)	REF
6-40 step 2mm	80-1-01-45-L

DRILL \varnothing 1.5mm
DRILL GUIDE
80-4-57-191-00
SCREWDRIVER 80-4-43-33-02.1
HANDLE 80-28-5-1
SHAFT s1,5 80-28-5-2

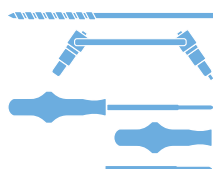

CORTICAL SCREWS self-tapping \varnothing 2,4



L (mm)	REF
8-60 step 2mm	80-1-01-239-L

DRILL \varnothing 1.8mm
DRILL GUIDE
80-4-57-183-00
SCREWDRIVER 80-4-57-33-00
HANDLE 80-28-5-1
SHAFT s2,5 80-28-5-3

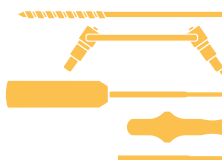

CORTICAL SCREWS self-tapping \varnothing 2,7



L (mm)	REF
8-60 step 2mm	80-1-01-48-L

DRILL \varnothing 2.0mm
DRILL GUIDE
80-4-57-192-00
SCREWDRIVER 80-4-57-33-00
HANDLE 80-28-5-1
SHAFT s2,5 80-28-5-3

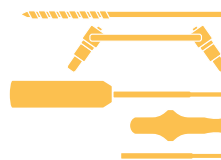

CORTICAL SCREWS self-tapping \varnothing 3,5

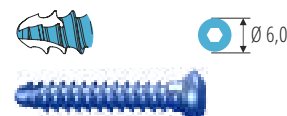

L (mm)	REF
10-70 step 2mm	80-1-01-51-L
70-90 step 5mm	

DRILL \varnothing 2.5mm
DRILL GUIDE
80-4-57-191-00
SCREWDRIVER 80-4-57-33-00
HANDLE 80-28-5-1
SHAFT 80-28-5-3

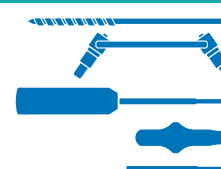

LOCKING COMPRESSION PANTARSAL ARTHRODESIS PLATES (for cats)
TITANIUM

locking screw \varnothing 2,0 mm

cortical and locking screw \varnothing 2,4 / 2,7 mm

THICKNESS	RIGHT	LEFT
2	80-1-25-215-01	80-1-25-216-01

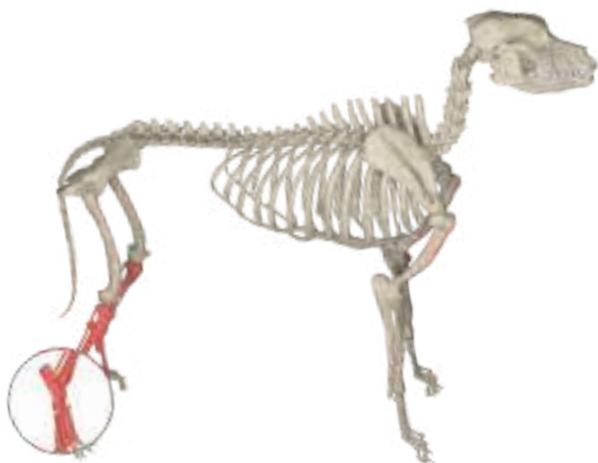
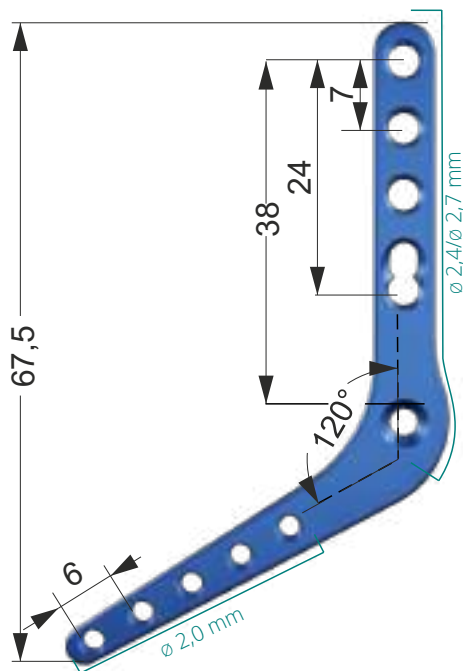

LOCKING SCREWS
self-tapping \varnothing 2,0



L (mm)	REF
6-40 step 2mm	80-1-01-260-L

CORTICAL SCREWS
self-tapping \varnothing 2,4



L (mm)	REF
8-60 step 2mm	80-1-01-239-L

LOCKING SCREWS
self-tapping \varnothing 2,4

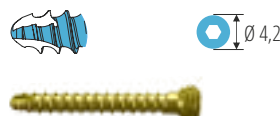

L (mm)	REF
8-40 step 2mm	80-1-01-200-L

CORTICAL SCREWS
self-tapping \varnothing 2,7



L (mm)	REF
8-60 step 2mm	80-1-01-48-L

LOCKING SCREWS
self-tapping \varnothing 2,7



L (mm)	REF
8-40 step 2mm	80-1-01-201-L

DRILL \varnothing 1.5mm
HOLDING SLEEVE 80-4-57-122-00
SCREWDRIVER 80-4-43-33-02.1



DRILL \varnothing 1.8mm
DRILL GUIDE 80-4-57-183-00
SCREWDRIVER 80-4-57-33-00
HANDLE 80-28-5-1
SHAFT s2,5 80-28-5-3



DRILL \varnothing 1.8mm
HOLDING SLEEVE 80-4-57-49-00
SCREWDRIVER 80-4-57-33-00
HANDLE 80-28-5-1
SHAFT s2,5 80-28-5-3



DRILL \varnothing 2.0mm
DRILL GUIDE 80-4-57-192-00
SCREWDRIVER 80-4-57-33-00
HANDLE 80-28-5-1
SHAFT s2,5 80-28-5-3

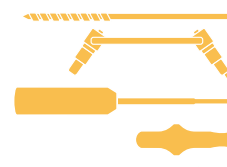

DRILL \varnothing 2.0mm
HOLDING SLEEVE 80-4-57-74-00
SCREWDRIVER 80-4-57-33-00
HANDLE 80-28-5-1
SHAFT s2,5 80-28-5-3



LOCKING COMPRESSION PANTARSAL ARTHRODESIS PLATES (for cats)
TITANIUM

cortical screw \varnothing 2,0 mm

cortical screw \varnothing 2,4 / 2,7 mm

THICKNESS	RIGHT	LEFT
2	80-1-25-211-01	80-1-25-212-01

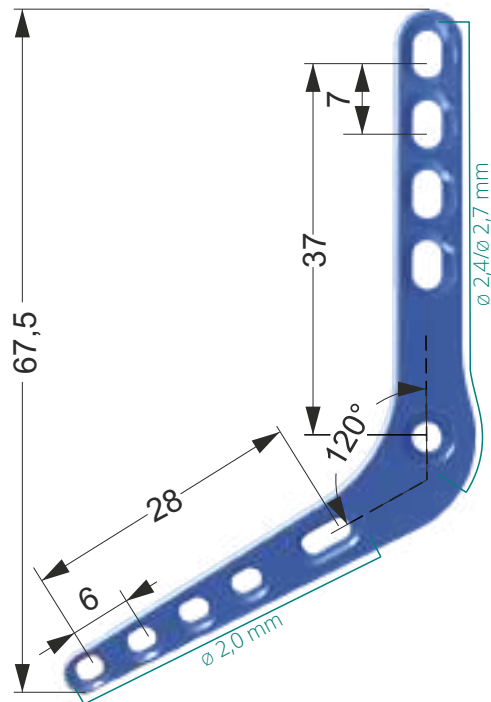

CORTICAL SCREWS
self-tapping \varnothing 2,0

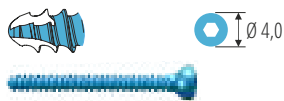

L (mm)	REF
6-40 step 2mm	80-1-01-45-L

CORTICAL SCREWS
self-tapping \varnothing 2,4



L (mm)	REF
8-60 step 2mm	80-1-01-239-L

CORTICAL SCREWS
self-tapping \varnothing 2,7



L (mm)	REF
8-60 step 2mm	80-1-01-48-L

DRILL \varnothing 1.5mm
DRILL GUIDE 80-4-57-191-00
SCREWDRIVER 80-4-43-33-02.1
HANDLE 80-28-5-1
SHAFT s1,5 80-28-5-2

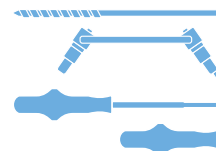

DRILL \varnothing 1.8mm
DRILL GUIDE 80-4-57-183-00
SCREWDRIVER 80-4-57-33-00
HANDLE 80-28-5-1
SHAFT s2,5 80-28-5-3

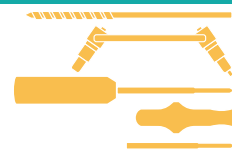

DRILL \varnothing 2.0mm
DRILL GUIDE 80-4-57-192-00
SCREWDRIVER 80-4-57-33-00
HANDLE 80-28-5-1
SHAFT s2,5 80-28-5-3

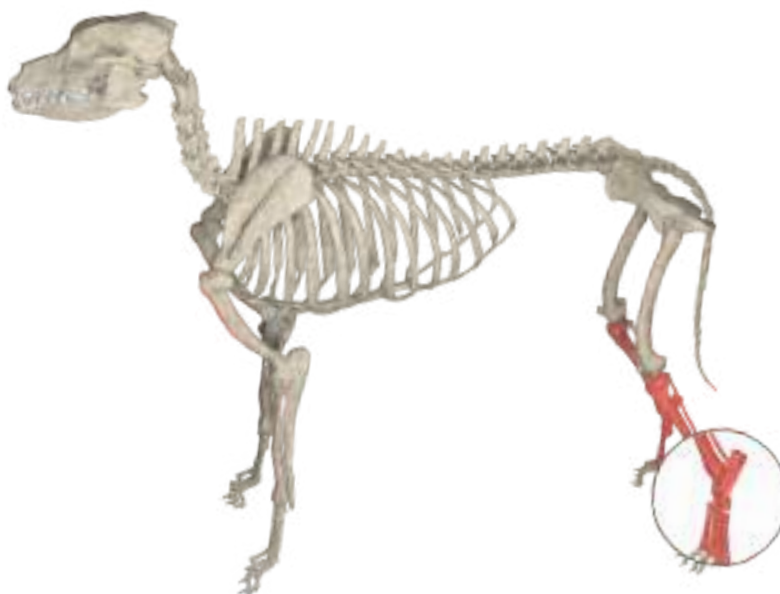
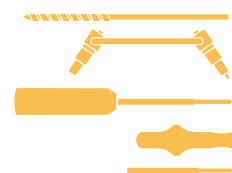

**CONDYLAR PLATE
TITANIUM**

cortical screw \varnothing 2,0 mm
locking screw \varnothing 2,0 mm

L [mm]	holes	RIGHT	LEFT
45	6	80-1-25-115-06	80-1-25-116-06
55	8	80-1-25-115-08	80-1-25-116-08
115	16	80-1-25-115-16	80-1-25-116-16

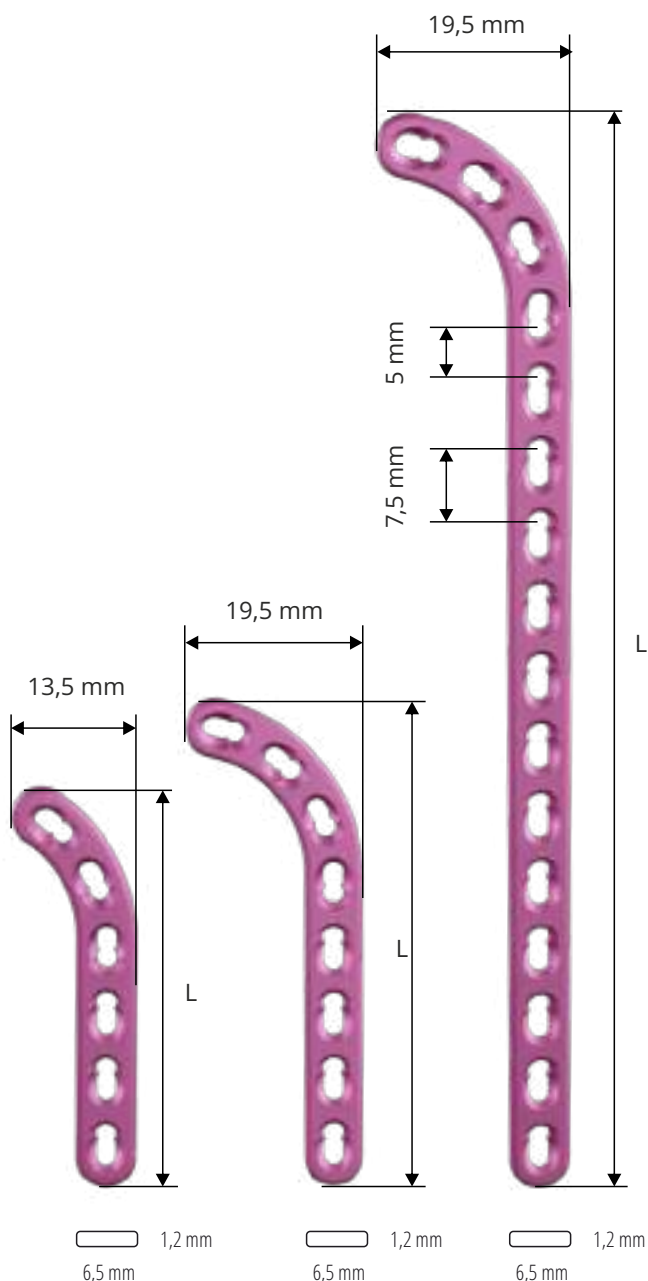

**CORTICAL SCREWS
self-tapping \varnothing 2,0**



L (mm) **REF**
6-40 | step 2mm 80-1-01-45-L

**LOCKING SCREWS
self-tapping \varnothing 2,0**



L (mm) **REF**
6-40 | step 2mm 80-1-01-260-L

DRILL \varnothing 1.5mm
DRILL GUIDE 80-4-57-191-00
SCREWDRIVER 80-4-43-33-02.1
HANDLE 80-28-5-1
SHAFT s1,5 80-28-5-2

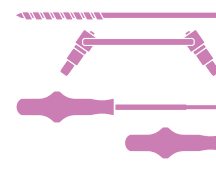

DRILL \varnothing 1.5mm
HOLDING SLEEVE 80-4-57-122-00
SCREWDRIVER 80-4-43-33-02.1
HANDLE 80-28-5-1
SHAFT s1,5 80-28-5-2

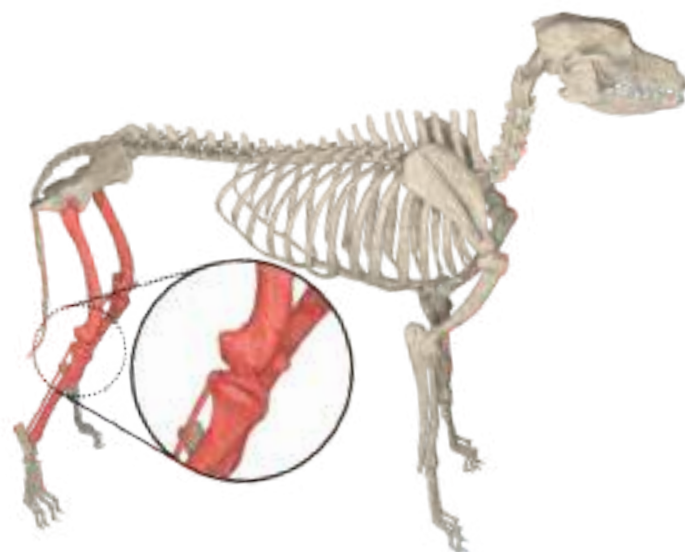
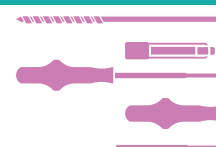

**CONDYLAR PALTE
TITANIUM**

cortical screw \varnothing 2,4 / 2,7 mm

locking screw \varnothing 2,4 / 2,7 mm

L [mm]	holes	RIGHT	LEFT
62	8	80-1-25-117-08	80-1-25-118-08
92	11	80-1-25-117-11	80-1-25-118-11

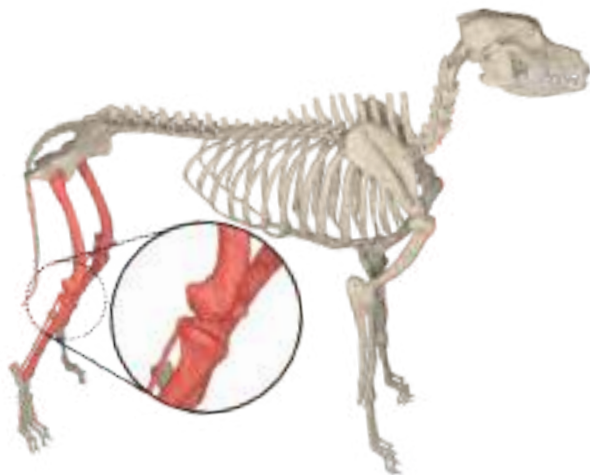
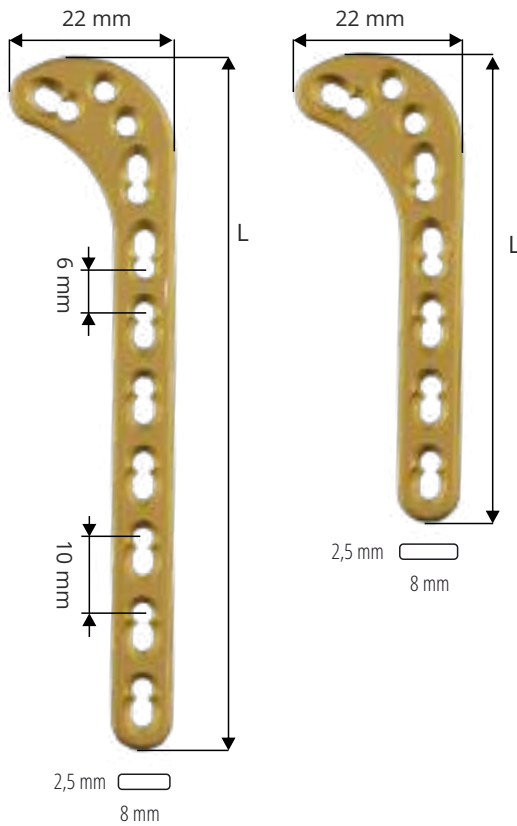

CORTICAL SCREWS

self-tapping \varnothing 2,4



L (mm)	REF
8-60 step 2mm	80-1-01-239-L

LOCKING SCREWS

self-tapping \varnothing 2,4



L (mm)	REF
8-40 step 2mm	80-1-01-200-L

LOCKING SCREWS

multi-angle \varnothing 2,4



L (mm)	T8
8-40 step 2mm	80-1-01-298-L

CORTICAL SCREWS

self-tapping \varnothing 2,7



L (mm)	REF
8-60 step 2mm	80-1-01-48-L

LOCKING SCREWS

self-tapping \varnothing 2,7



L (mm)	REF
8-40 step 2mm	80-1-01-201-L

LOCKING SCREWS

multi-angle \varnothing 2,7



L (mm)	REF
10-40 step 2mm	80-1-01-325-L

DRILL \varnothing 1.8mm
DRILL GUIDE 80-4-57-183-00
SCREWDRIVER 80-4-57-33-00
HANDLE 80-28-5-1
SHAFT s2,5 80-28-5-3



DRILL \varnothing 1.8mm
HOLDING SLEEVE 80-4-57-49-00
SCREWDRIVER 80-4-57-33-00
HANDLE 80-28-5-1
SHAFT s2,5 80-28-5-3



DRILL \varnothing 1.8mm
VARIABLE ANGLE SLEEVE 80-4-57-171-01
SCREWDRIVER T8 80-4-57-76-00
HANDLE 80-28-5-1
SHAFT T8 80-4-43-45-16.1



DRILL \varnothing 2.0mm
DRILL GUIDE 80-4-57-192-00
SCREWDRIVER 80-4-57-33-00
HANDLE 80-28-5-1
SHAFT s2,5 80-28-5-3



DRILL \varnothing 2.0mm
HOLDING SLEEVE 80-4-57-74-00
SCREWDRIVER 80-4-57-33-00
HANDLE 80-28-5-1
SHAFT s2,5 80-28-5-3



DRILL \varnothing 2.0mm
VARIABLE ANGLE SLEEVE 80-4-57-171-02
SCREWDRIVER T8 4-57-76-00
HANDLE 80-28-5-1
SHAFT 80-4-43-45-16.1



**CONDYLAR PLATE
TITANIUM**

cortical screw \varnothing 3,5 mm

locking screw \varnothing 3,5 mm

L [mm]	holes	RIGHT	LEFT
123	11	80-1-25-119-11	80-1-25-120-11
161	14	80-1-25-119-14	80-1-25-120-14

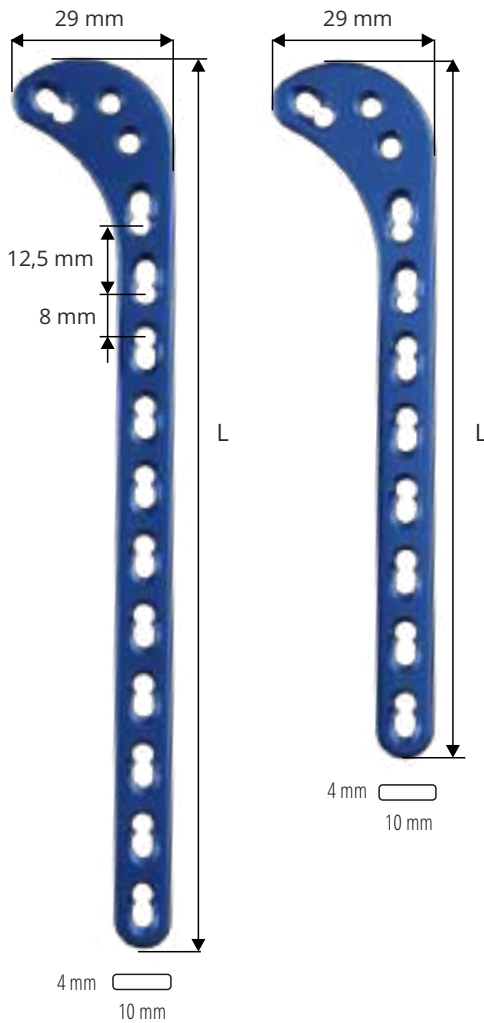

**CORTICAL SCREWS
self-tapping**

\varnothing 3,5

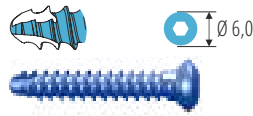

L (mm)	REF
10-70 step 2mm	
70-90 step 5mm	80-1-01-51-L

**LOCKING SCREWS
self-tapping**

\varnothing 3,5

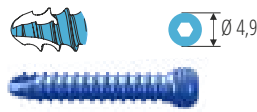

L (mm)	REF
10-60 step 2mm	
70-95 step 5mm	80-1-01-11-L

**LOCKING SCREWS
multi-angle \varnothing 3,5**



L (mm)	REF
10-60 step 2mm	
60-95 step 5mm	80-1-01-322-L

DRILL \varnothing 2.5mm
DRILL GUIDE 80-4-57-191-00
SCREWDRIVER 80-4-57-33-00
HANDLE 80-28-5-1
SHAFT 80-28-5-3

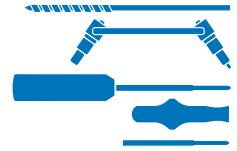

DRILL \varnothing 2.7mm
HOLDING SLEEVE 80-4-57-51-00
SCREWDRIVER 80-4-57-33-00
HANDLE 80-28-5-1
SHAFT s2,5 80-28-5-3



DRILL \varnothing 2.7mm
VARIABLE ANGLE SLEEVE
80-4-57-171-03
SCREWDRIVER T15 80-4-57-181-00
HANDLE 80-28-5-1
SHAFT T15 80-4-43-45-22.1

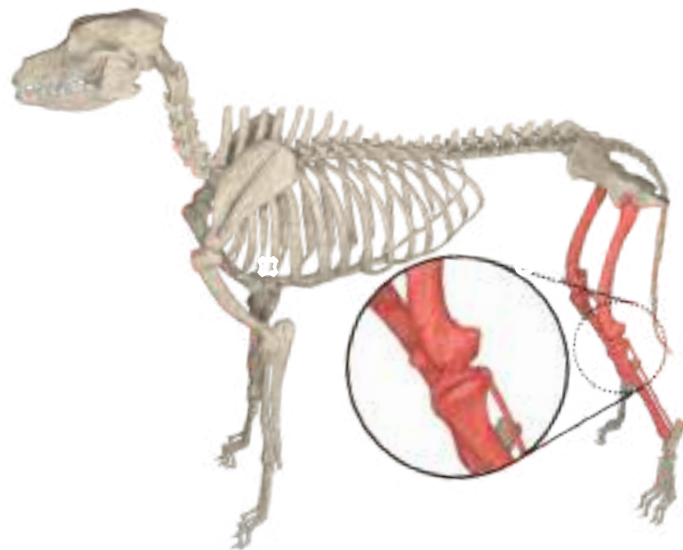
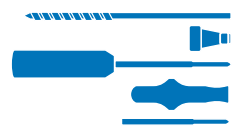

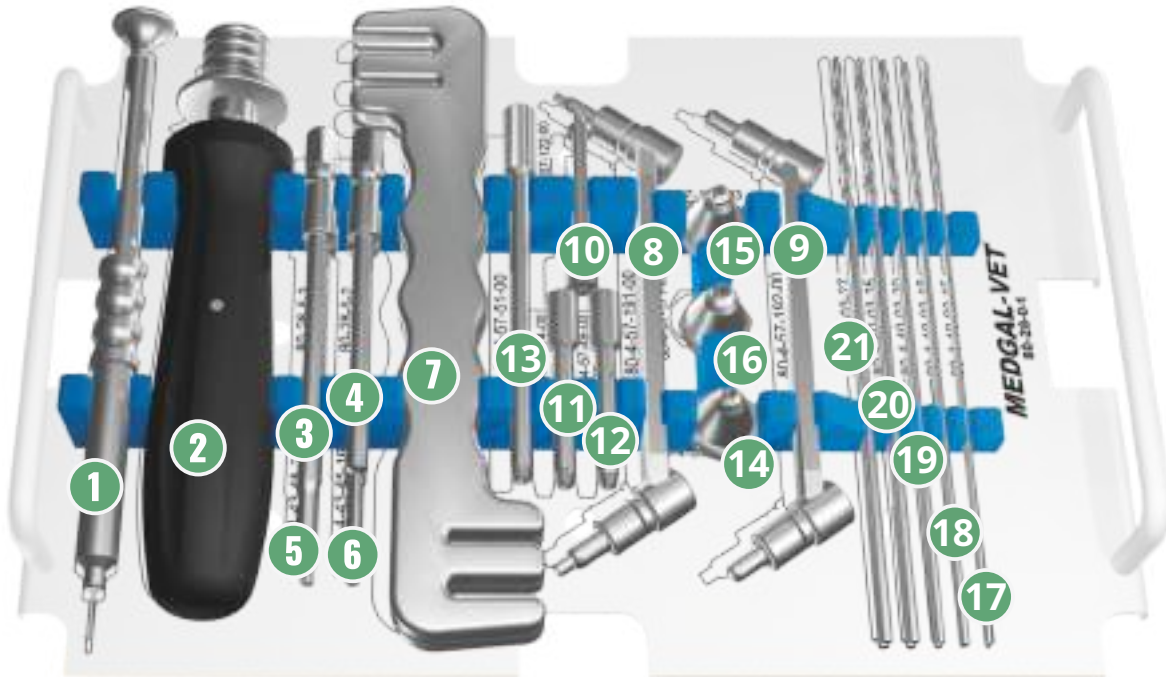

SCREWS SELECTION TABLE

Istruments set elements	REF No.	SCREWS										
		CORTICAL				LOCKING				MULTI-ANGLE LOCKING		
		2,0	2,4	2,7	3,5	2,0	2,4	2,7	3,5	2,4	2,7	3,5
1 Bone thickness gauge	80-4-57-69-00	+	+	+	+	+	+	+	+	+	+	+
2 Handle for variable shafts	80-28-5-1	+	+	+	+	+	+	+	+	+	+	+
3 Shaft S 2,5	80-28-5-3		+	+	+		+	+	+			
4 Shaft S 1,5	80-28-5-2	+				+						
5 Shaft TORX T15	80-4-43-45-22.1											+
6 Shaft TORX T8	80-4-43-45-16.1									+	+	
7 Double bending iron for plates	80-28-3-1	+	+	+	+	+	+	+	+	+	+	+
8 Compression drill guide ø 1,5 i 2,5	80-4-57-191-00	+			+							
9 Compression drill guide ø 1,8 i 2,0	80-4-57-192-00		+	+								
10 Guide with screw lenght measurment ø 1,5	80-4-57-122-00					+						
11 Drill sleeve ø 1,8	80-4-57-49-00						+					
12 Drill sleeve ø 2,0	80-4-57-74-00							+				
13 Drill sleeve ø 2,7	80-4-57-51-00								+			
14 Threaded conical sleeve ø 1,8	80-4-57-171-01									+		
15 Threaded conical sleeve ø 2,1	80-4-57-171-02										+	
16 Threaded conical sleeve ø 2,7	80-4-57-171-03											+
17 Drill ø 1,5	80-4-40-03-15	+				+						
18 Drill ø 1,8	80-4-40-03-18		+				+			+		
19 Drill ø 2,0	80-4-40-03-20			+				+			+	
20 Drill ø 2,5	80-4-40-03-25				+							
21 Drill ø 2,7	80-4-40-03-27								+			+

+

 screws ø 2,0

+

 screws ø 2,4/2,7

+

 screws ø 3,5



SCREW CASE
80-28-0-1.2

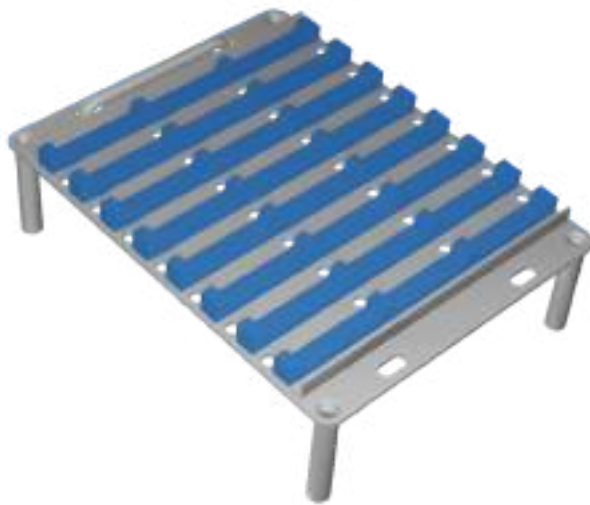

CASE FOR STERILIZING PLATES
80-28-0-1.3



**Instrument set with a case for screws and a case for sterilizing plates
fit in the veterinary container (80-4-99-25-65)**



SYSTEM

2.4

2.7

SCREW CASE WITH COVER
80-4-99-01-37



SYSTEM

3,5

SCREW CASE WITH COVER
80-4-99-01-36

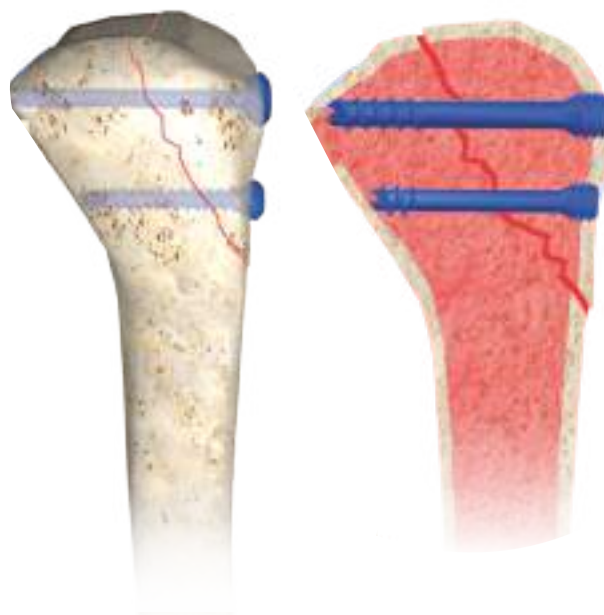

CANCELLOUS SCREWS - self-tapping - Ø 4,0

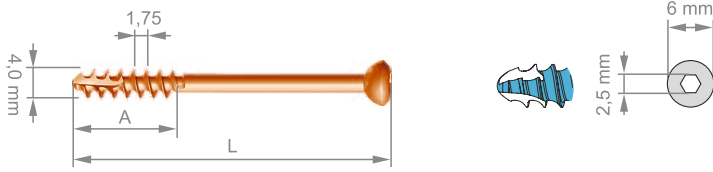

L (mm)	A (mm)	⊙	L (mm)	A (mm)	⊙
10	5	80-X-01-12-10	30	14	80-X-01-12-30
12	5	80-X-01-12-12	35	14	80-X-01-12-35
14	5	80-X-01-12-14	40	14	80-X-01-12-40
16	6	80-X-01-12-16	45	15	80-X-01-12-45
18	7	80-X-01-12-18	50	16	80-X-01-12-50
20	9	80-X-01-12-20	55	16	80-X-01-12-55
22	9	80-X-01-12-22	60	16	80-X-01-12-60
24	10	80-X-01-12-24	65	16	80-X-01-12-65
26	12	80-X-01-12-26	70	16	80-X-01-12-70
28	14	80-X-01-12-28			

CANNULATED SCREWS - self-drilling - Ø 2,4



L (mm)	A (mm)	⊙	L (mm)	A (mm)	⊙
17	5	80-X-01-286-17	24	6	80-X-01-286-24
18	5	80-X-01-286-18	26	6	80-X-01-286-26
19	5	80-X-01-286-19	28	6	80-X-01-286-28
20	5	80-X-01-286-20	30	6	80-X-01-286-30
22	5	80-X-01-286-22			

CANNULATED SCREWS - self-drilling - Ø 2,4



L (mm)	A (mm)	⊙	L (mm)	A (mm)	⊙
10	4	80-X-01-285-10	18	8	80-X-01-285-18
11	5	80-X-01-285-11	19	9	80-X-01-285-19
12	5	80-X-01-285-12	20	9	80-X-01-285-20
13	6	80-X-01-285-13	22	10	80-X-01-285-22
14	6	80-X-01-285-14	24	10	80-X-01-285-24
15	7	80-X-01-285-15	26	12	80-X-01-285-26
16	7	80-X-01-285-16	28	12	80-X-01-285-28
17	8	80-X-01-285-17	30	14	80-X-01-285-30

SCREWDRIVER s2,5
80-4-57-33-00
lub
HANDLE 80-28-5-1
SHAFT 80-28-5-3
DRILL 1,8
80-4-40-03-18
DRILL GUIDE
80-4-57-49-00

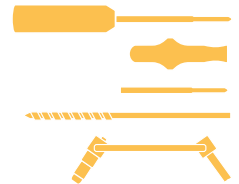

KIRSCHNER GUIDE 80-4-48-01-15
WIRE 0,8 80-4-06-01-23
PARALEL GUIDE
80-4-48-01-22
GAUGE 80-4-48-01-20
CANNULATED DRILL 1,8
80-4-48-03-01
DRILL GUIDE 1,8
80-4-48-03-03
COUNTERSINK 80-28-2-4.60
CANNULATED SCREWDRIVER s2,5
80-4-48-01-49

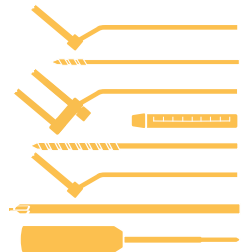

KIRSCHNER GUIDE 80-4-48-01-15
WIRE 0,8 80-4-06-01-23
PARALEL GUIDE
80-4-48-01-22
GAUGE 80-4-48-01-20
CANNULATED DRILL 1,8
80-4-48-03-01
DRILL GUIDE 1,8
80-4-48-03-03
COUNTERSINK 80-28-2-4.60
CANNULATED SCREWDRIVER s2,5
80-4-48-01-49

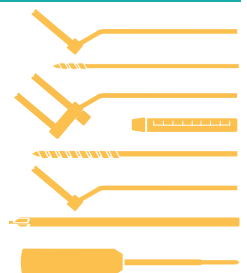

CANNULATED SCREWS -self-dilling - \varnothing 3,5

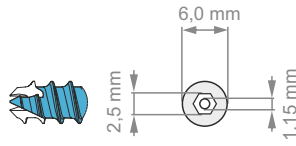
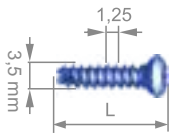

L (mm)	⊙	L (mm)	⊙
8	80-X-01-100-08	40	80-X-01-100-40
10	80-X-01-100-10	42	80-X-01-100-42
12	80-X-01-100-12	44	80-X-01-100-44
14	80-X-01-100-14	46	80-X-01-100-46
16	80-X-01-100-16	48	80-X-01-100-48
18	80-X-01-100-18	50	80-X-01-100-50
20	80-X-01-100-20	52	80-X-01-100-52
22	80-X-01-100-22	54	80-X-01-100-54
24	80-X-01-100-24	56	80-X-01-100-56
26	80-X-01-100-26	58	80-X-01-100-58
28	80-X-01-100-28	60	80-X-01-100-60
30	80-X-01-100-30	62	80-X-01-100-62
32	80-X-01-100-32	64	80-X-01-100-64
34	80-X-01-100-34	66	80-X-01-100-66
36	80-X-01-100-36	68	80-X-01-100-68
38	80-X-01-100-38	70	80-X-01-100-70

KIRSCHNER GUIDE 80-4-48-01-15
 WIRE 1.0 80-4-06-02-23
 PARALEL GUIDE 1,2
 80-4-48-01-22
 GAUGE 80-4-48-01-20
 CANNULATED DRILL 2,4
 80-4-48-03-10
 DRILL GUIDE 2,4
 80-4-48-03-15
 COUNTERSINK 80-28-2-4.60
 CANNULATED SCREWDRIVER s2,5
 80-4-48-01-49

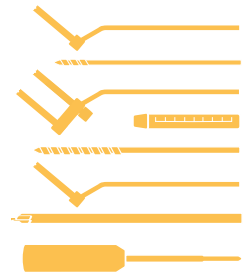

CANNULATED SCREWS-self-drilling- \varnothing 3,5

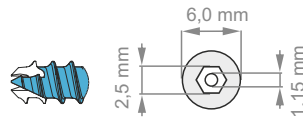
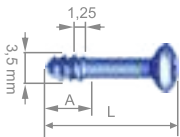

L (mm)	A (mm)	⊙	L (mm)	A (mm)	⊙
10	4	80-X-01-101-10	36	12	80-X-01-101-36
12	4	80-X-01-101-12	38	12	80-X-01-101-38
14	5	80-X-01-101-14	40	13	80-X-01-101-40
16	5	80-X-01-101-16	42	14	80-X-01-101-42
18	6	80-X-01-101-18	44	14	80-X-01-101-44
20	7	80-X-01-101-20	46	15	80-X-01-101-46
22	7	80-X-01-101-22	48	15	80-X-01-101-48
24	8	80-X-01-101-24	50	16	80-X-01-101-50
26	8	80-X-01-101-26	52	16	80-X-01-101-52
28	9	80-X-01-101-28	54	17	80-X-01-101-54
30	10	80-X-01-101-30	56	18	80-X-01-101-56
32	11	80-X-01-101-32	58	19	80-X-01-101-58
34	11	80-X-01-101-34	60	20	80-X-01-101-60

KIRSCHNER GUIDE 1,2
 80-4-48-01-15
 WIRE 1,0 80-4-06-02-23
 PARALEL GUIDE 1,2
 80-4-48-01-22
 GAUGE 80-4-48-01-20
 CANNULATED DRILL 2,4
 80-4-48-03-10
 DRILL GUIDE 2,4 80-4-48-08-15
 COUNTERSINK 80-28-2-4.60
 CANNULATED SCREWDRIVER s2,5
 80-4-48-01-49

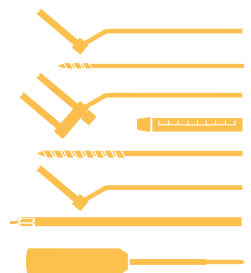

CANNULATED SCREWS -self-drilling Ø 4,0

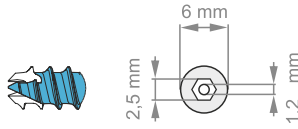
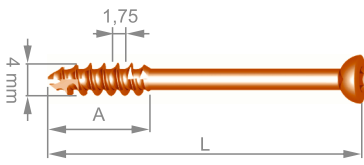

L (mm)	A (mm)	○	L (mm)	A (mm)	○
10	5	80-X-01-231-10	42	14	80-X-01-231-42
12	5	80-X-01-231-12	44	14	80-X-01-231-44
14	5	80-X-01-231-14	46	15	80-X-01-231-46
16	5	80-X-01-231-16	48	15	80-X-01-231-48
18	6	80-X-01-231-18	50	16	80-X-01-231-50
20	7	80-X-01-231-20	52	17	80-X-01-231-52
22	7	80-X-01-231-22	54	18	80-X-01-231-54
24	8	80-X-01-231-24	56	19	80-X-01-231-56
26	9	80-X-01-231-26	58	19	80-X-01-231-58
28	9	80-X-01-231-28	60	20	80-X-01-231-60
30	10	80-X-01-231-30	62	21	80-X-01-231-62
32	11	80-X-01-231-32	64	21	80-X-01-231-64
34	11	80-X-01-231-34	66	22	80-X-01-231-66
36	12	80-X-01-231-36	68	23	80-X-01-231-68
38	12	80-X-01-231-38	70	23	80-X-01-231-70
40	13	80-X-01-231-40	72	24	80-X-01-231-72

- KIRSCHNER GUIDE 1,2
80-4-48-01-15
- WIRE 1,0 80-4-06-02-23
- PARALEL GUIDE
80-4-48-01-22
- GAUGE 80-4-48-01-20
- CANNULATED DRILL 2,6
80-4-48-03-17
- DRILL GAUGE 2,6
80-4-48-03-15
- COUNTERSINK 80-28-2-4.60
- CANNULATED SCREWDRIVER s2,5
80-4-48-01-49

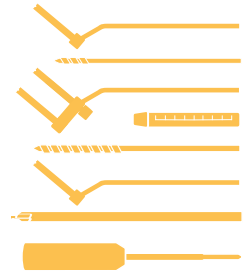

CANNULATED SCREWS -self-drilling Ø 4,0

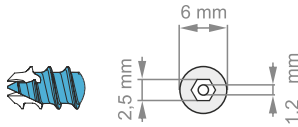
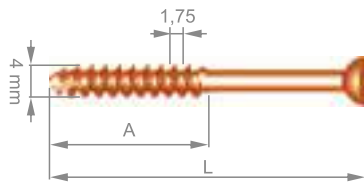

L (mm)	A (mm)	○	L (mm)	A (mm)	○
16	8	80-X-01-232-16	46	23	80-X-01-232-46
18	9	80-X-01-232-18	48	24	80-X-01-232-48
20	10	80-X-01-232-20	50	25	80-X-01-232-50
22	11	80-X-01-232-22	52	26	80-X-01-232-52
24	12	80-X-01-232-24	54	27	80-X-01-232-54
26	13	80-X-01-232-26	56	28	80-X-01-232-56
28	14	80-X-01-232-28	58	29	80-X-01-232-58
30	15	80-X-01-232-30	60	30	80-X-01-232-60
32	16	80-X-01-232-32	62	31	80-X-01-232-62
34	17	80-X-01-232-34	64	32	80-X-01-232-64
36	18	80-X-01-232-36	66	33	80-X-01-232-66
38	19	80-X-01-232-38	68	34	80-X-01-232-68
40	20	80-X-01-232-40	70	35	80-X-01-232-70
42	21	80-X-01-232-42	72	36	80-X-01-232-72
44	22	80-X-01-232-44			

- KIRSCHNER GUIDE 1,2
80-4-48-01-15
- WIRE 1,0 80-4-06-02-23
- PARALEL GUIDE
80-4-48-01-22
- GAUGE 80-4-48-01-20
- CANNULATED DRILL 2,6
80-4-48-03-17
- DRILL GUIDE 2,6
80-4-48-03-15
- COUNTERSINK 80-28-2-4.60
- CANNULATED SCREWDRIVER s2,5
80-4-48-01-49

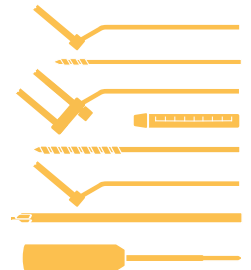

COMPRESSION CANNULATED SCREWS Ø 2,4/3,3

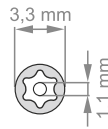
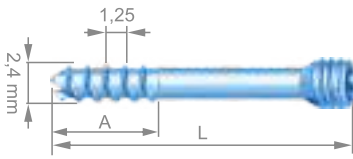

L (mm)	A (mm)	⊕	L (mm)	A (mm)	⊕
14	5	80-X-01-272-14	26	10	80-X-01-272-26
16	5	80-X-01-272-16	27	10	80-X-01-272-27
17	6	80-X-01-272-17	28	10	80-X-01-272-28
18	6	80-X-01-272-18	29	10	80-X-01-272-29
19	7	80-X-01-272-19	30	12	80-X-01-272-30
20	7	80-X-01-272-20	32	12	80-X-01-272-32
21	8	80-X-01-272-21	34	14	80-X-01-272-34
22	8	80-X-01-272-22	36	14	80-X-01-272-36

TORX SCREWDRIVER T8 80-4-59-13-00
 COMPRESSION SLEEVE
 2,4 80-4-59-12-24
 KIRSHNER WIRE 1,0 80-4-06-02-15
 GUIDE 1,1/2,0 80-4-59-10-00
 CANNULATED DRILL 2,0
 80-4-59-09-00
 GAUGE 40mm 80-4-59-11-00

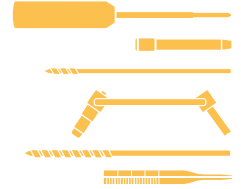

COMPRESSION CANNULATED SCREWS Ø 3,0/3,5

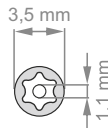
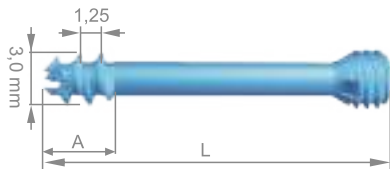

L (mm)	A (mm)	⊕	L (mm)	A (mm)	⊕
10	4	80-X-01-294-10	23	4	80-X-01-294-23
11	4	80-X-01-294-11	24	5	80-X-01-294-24
12	4	80-X-01-294-12	25	5	80-X-01-294-25
13	4	80-X-01-294-13	26	5	80-X-01-294-26
14	4	80-X-01-294-14	27	6	80-X-01-294-27
15	4	80-X-01-294-15	28	6	80-X-01-294-28
16	4	80-X-01-294-16	29	6	80-X-01-294-29
17	4	80-X-01-294-17	30	7	80-X-01-294-30
18	4	80-X-01-294-18	32	7	80-X-01-294-32
19	4	80-X-01-294-19	34	8	80-X-01-294-34
20	4	80-X-01-294-20	36	9	80-X-01-294-36
21	4	80-X-01-294-21	38	9	80-X-01-294-38
22	4	80-X-01-294-22	40	10	80-X-01-294-40

TORX SCREWDRIVER T8 80-4-59-13-00
 COMPRESSION SLEEVE 3,0 80-4-59-12-30
 KIRSHNER WIRE 1,0 80-4-06-02-15
 GUIDE 1,1/2,0 80-4-59-10-00
 CANNULATED DRILL 2,0
 80-4-59-09-00
 GAUGE 40mm 80-4-59-11-00

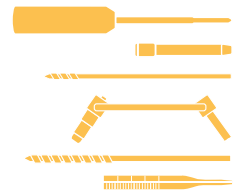

COMPRESSION CANNULATED SCREWS Ø 3,0/3,5

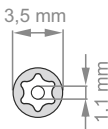
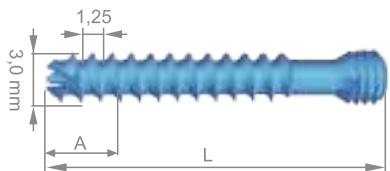

L (mm)	A (mm)	⊕	L (mm)	A (mm)	⊕
14	5	80-X-01-295-14	26	10	80-X-01-295-26
16	5	80-X-01-295-16	27	10	80-X-01-295-27
17	6	80-X-01-295-17	28	10	80-X-01-295-28
18	6	80-X-01-295-18	29	10	80-X-01-295-29
19	7	80-X-01-295-19	30	12	80-X-01-295-30
20	7	80-X-01-295-20	32	12	80-X-01-295-32
21	8	80-X-01-295-21	34	14	80-X-01-295-34
22	8	80-X-01-295-22	36	14	80-X-01-295-36
23	8	80-X-01-295-23	38	16	80-X-01-295-38
24	8	80-X-01-295-24	40	16	80-X-01-295-40
25	8	80-X-01-295-25			

TORX SCREWDRIVER T8 80-4-59-13-00
 COMPRESSION SLEEVE 3,0 80-4-59-12-30
 KIRSHNER WIRE 1,0 80-4-06-02-15
 GUIDE 1,1/2,0 80-4-59-10-00
 CANNULATED DRILL 2,0
 80-4-59-09-00
 GAUGE 40mm 80-4-59-11-00

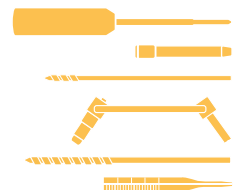

CANNULATED COMPRESSION SCREWS Ø 4,5/5,0

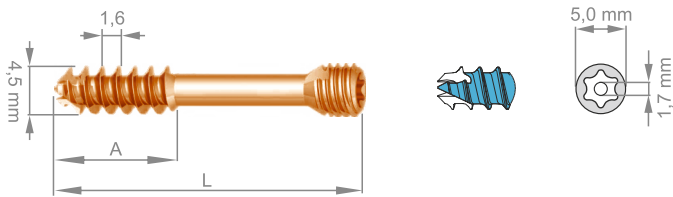

L (mm)	A (mm)	⊕	L (mm)	A (mm)	⊕
30	12	80-X-01-274-30	56	22	80-X-01-274-56
32	12	80-X-01-274-32	58	22	80-X-01-274-58
34	12	80-X-01-274-34	60	24	80-X-01-274-60
36	14	80-X-01-274-36	65	26	80-X-01-274-65
38	14	80-X-01-274-38	70	28	80-X-01-274-70
40	16	80-X-01-274-40	75	30	80-X-01-274-75
42	16	80-X-01-274-42	80	32	80-X-01-274-80
44	18	80-X-01-274-44	85	34	80-X-01-274-85
46	18	80-X-01-274-46	90	36	80-X-01-274-90
48	18	80-X-01-274-48	95	38	80-X-01-274-95
50	20	80-X-01-274-50	100	40	80-X-01-274-100

TORX SCREWDRIVER T15 80-4-59-13-02
 COMPRESSION SLEEVE 4,5 80-4-59-12-45
 KIRSHNER WIRE 1,6 80-4-06-05-22
 GUIDE 3,2/1,6 80-4-59-10-01
 CANNULATED DRILL 3,2
 80-4-59-09-01
 GAUGE 110mm 80-4-59-11-01

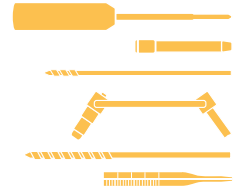

CANNULATED COMPRESSION SCREWS Ø 4,5/5,0

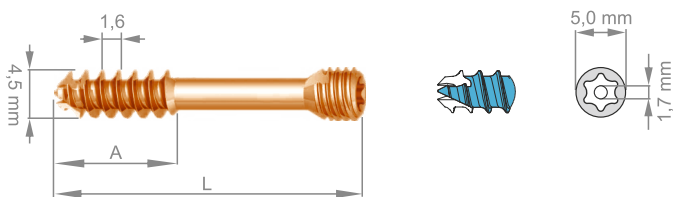

L (mm)	A (mm)	⊕	L (mm)	A (mm)	⊕
20	7	80-X-01-273-20	42	8	80-X-01-273-42
22	7	80-X-01-273-22	44	9	80-X-01-273-44
24	7	80-X-01-273-24	46	9	80-X-01-273-46
26	7	80-X-01-273-26	48	9	80-X-01-273-48
28	7	80-X-01-273-28	50	10	80-X-01-273-50
30	7	80-X-01-273-30	52	10	80-X-01-273-52
32	7	80-X-01-273-32	54	11	80-X-01-273-54
34	7	80-X-01-273-34	56	11	80-X-01-273-56
36	7	80-X-01-273-36	58	11	80-X-01-273-58
38	7	80-X-01-273-38	60	12	80-X-01-273-60
40	8	80-X-01-273-40	65	13	80-X-01-273-65

TORX SCREWDRIVER T15 80-4-59-13-02
 COMPRESSION SLEEVE 4,5 80-4-59-12-45
 KIRSHNER WIRE 1,6 80-4-06-05-22
 GUIDE 3,2/1,6 80-4-59-10-01
 CANNULATED DRILL 3,2
 80-4-59-09-01
 GUGE 110mm 80-4-59-11-01

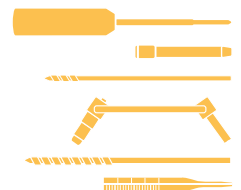

CANNULATED SCREW INSTRUMENTS SET

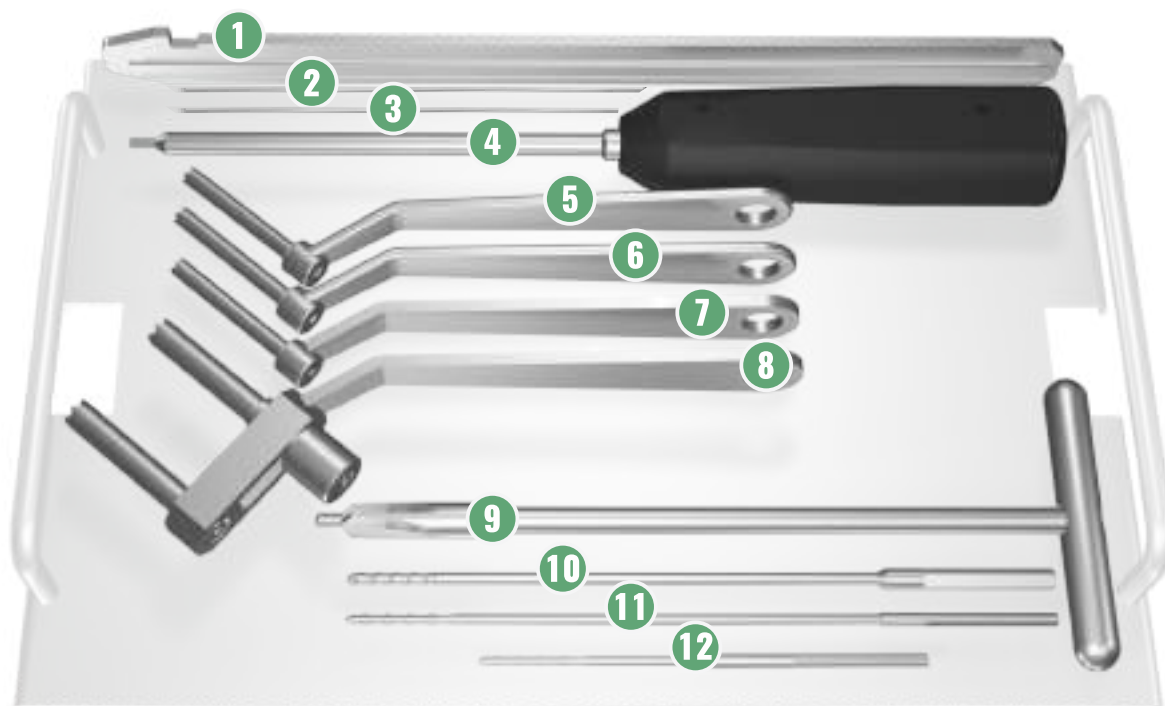

1	Gauge	80-4-48-01-20
2	2x Wire Ø 0,8	80-4-06-01-23
3	2x Wire Ø 1,0	80-4-06-02-23
4	Cannulated screwdriver - s2,5	80-4-48-01-49
5	Drill guide Ø 2,4/2,6	80-4-48-03-15
6	Drill guide Ø 1,8	80-4-48-03-03
7	Kirschner guide Ø 1,0	80-4-48-01-15
8	Paralel guide	80-4-48-01-22
9	Countersink	80-28-2-4.60
10	Cannulated drill Ø 2,6	80-4-48-03-17
11	Cannulated drill Ø 2,4	80-4-48-03-10
12	Cannulated drill Ø 1,8	80-4-48-03-01

COMPRESSION SCREW INSTRUMENTS SET

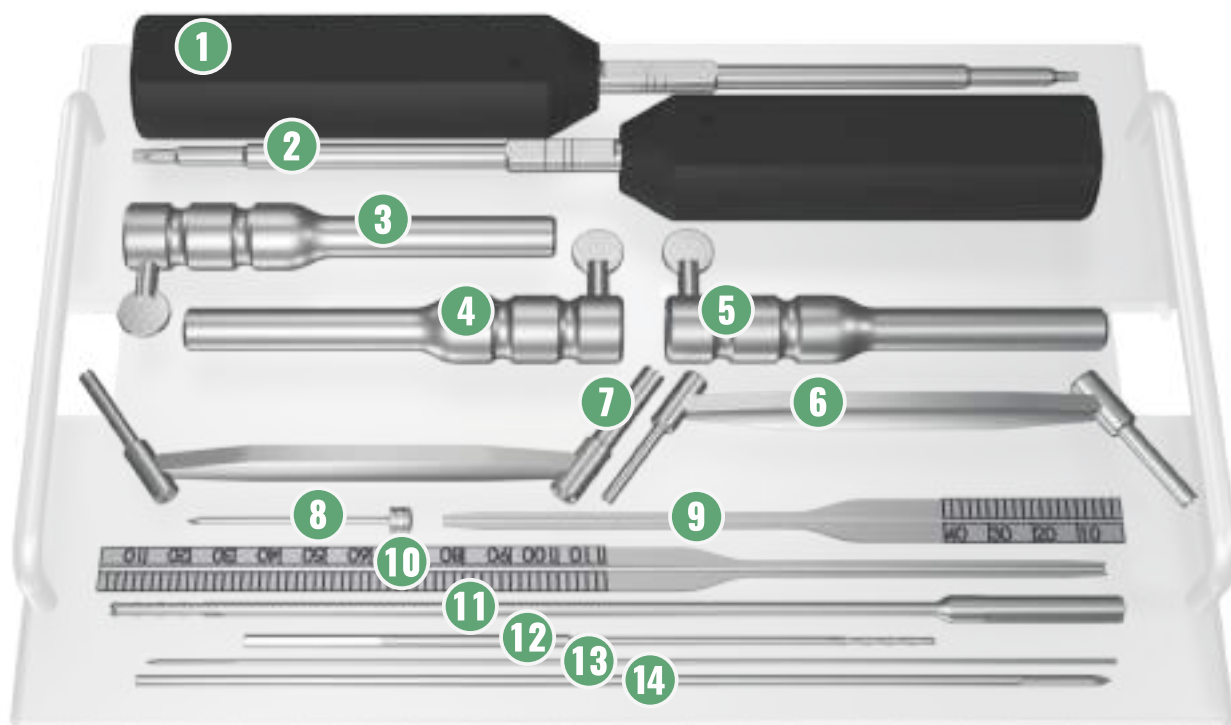

1	TORX Screwdriver T8	80-4-59-13-00
2	TORX Screwdriver T15	80-4-59-13-02
3	Compression sleeve Ø 2,4	80-4-59-12-24
4	Compression sleeve Ø 3,0	80-4-59-12-30
5	Compression sleeve Ø 4,5	80-4-59-12-45
6	Guide Ø 2,0 + 1,1 mm	80-4-59-10-00
7	Guide Ø 3,2 + 1,6 mm	80-4-59-10-01
8	Trocar Ø 1,6	80-4-59-14-16
9	Gauge 40 mm	80-4-59-11-00
10	Gauge 110 mm	80-4-59-11-01
11	Cannulated drill Ø 2,0, 150 mm	80-4-59-09-00
12	Cannulated drill Ø 3,2, 220 mm	80-4-59-09-01
13	Kirshner wire Ø 1,0, 150 mm	80-4-06-02-15
14	Kirshner wire Ø 1,6, 220 mm	80-4-06-05-22

INTRAMEDULLARY NAILS



INTRAMEDULLARY NAIL

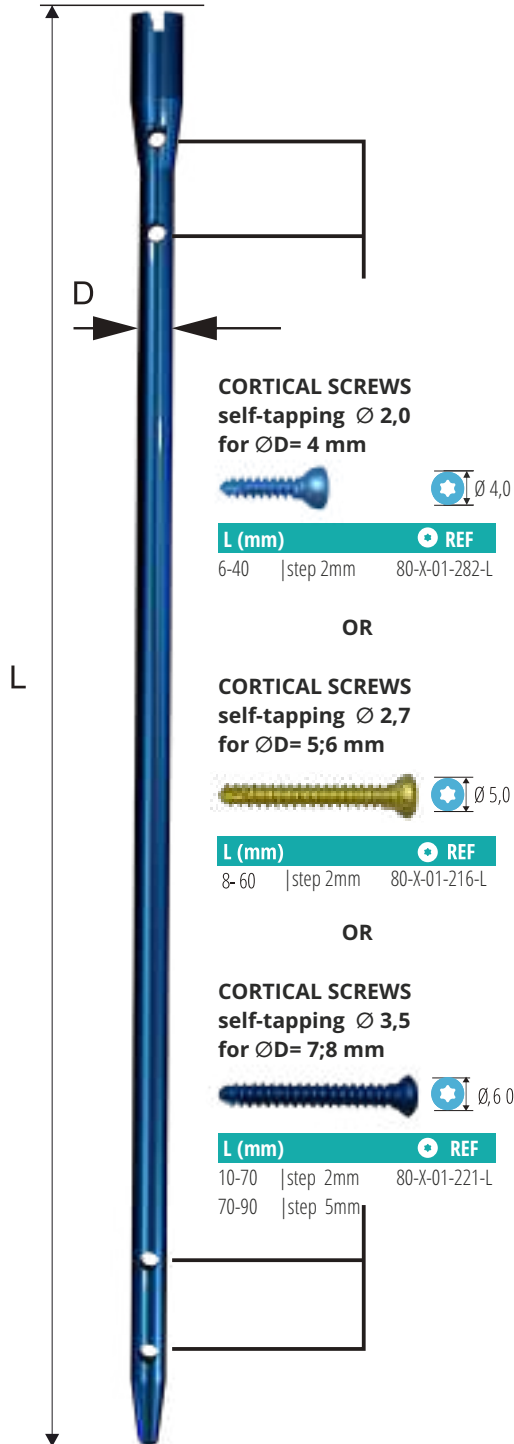

L	\varnothing D=4 mm	\varnothing D=5 mm	\varnothing D=6 mm	\varnothing D=7 mm	\varnothing D=8 mm
70	80-1-25-704-70	80-1-25-705-70	80-1-25-706-70	80-1-25-707-70	80-1-25-709-70
81	80-1-25-704-81	80-1-25-705-81	80-1-25-706-81	80-1-25-707-81	80-1-25-709-81
92	80-1-25-704-92	80-1-25-705-92	80-1-25-706-92	80-1-25-707-92	80-1-25-709-92
103	80-1-25-704-103	80-1-25-705-103	80-1-25-706-103	80-1-25-707-103	80-1-25-709-103
114	80-1-25-704-114	80-1-25-705-114	80-1-25-706-114	80-1-25-707-114	80-1-25-709-114
125	80-1-25-704-125	80-1-25-705-125	80-1-25-706-125	80-1-25-707-125	80-1-25-709-125
136	80-1-25-704-136	80-1-25-705-136	80-1-25-706-136	80-1-25-707-136	80-1-25-709-136
147	80-1-25-704-147	80-1-25-705-147	80-1-25-706-147	80-1-25-707-147	80-1-25-709-147
158	80-1-25-704-158	80-1-25-705-158	80-1-25-706-158	80-1-25-707-158	80-1-25-709-158
169	80-1-25-704-169	80-1-25-705-169	80-1-25-706-169	80-1-25-707-169	80-1-25-709-169
180	-	-	80-1-25-706-180	80-1-25-707-180	80-1-25-709-180
191	-	-	80-1-25-706-191	80-1-25-707-191	80-1-25-709-191
202	-	-	80-1-25-706-202	80-1-25-707-202	80-1-25-709-202

INTRAMEDULLARY NAILS INSTRUMENTS SET

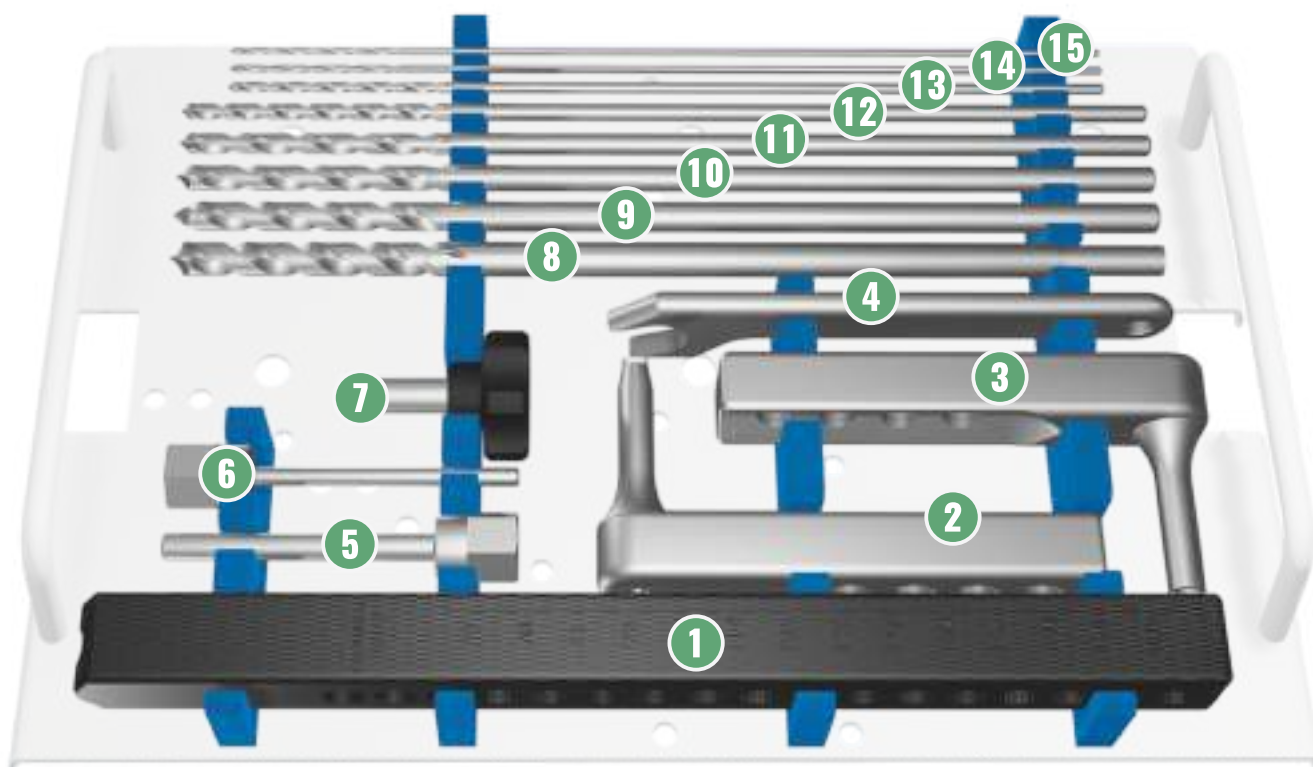

1	Targeting device	80-28-6-2.1
2	Nail handle ø6	80-28-6-2.2.60
3	Nail handle ø8	80-28-6-2.2.80
4	Wrench 14 mm	80-4-50-00-41
5	Nail holding screw M6	80-28-7-1.M6
6	Nail holding screw M4	80-28-7-1.M4
7	Tightening screw M8	80-28-7-4
8	Drill ø9	80-4-40-15-90
9	Drill ø8	80-4-40-15-80
10	Drill ø7	80-4-40-15-70
11	Drill ø6	80-4-40-15-60
12	Drill ø5	80-4-40-15-50
13	Drill ø2,5	80-4-40-08-25
14	Drill ø1,8	80-4-40-08-18
15	Drill ø1,5	80-4-40-08-15

INTRAMEDULLARY NAILS INSTRUMENTS SET

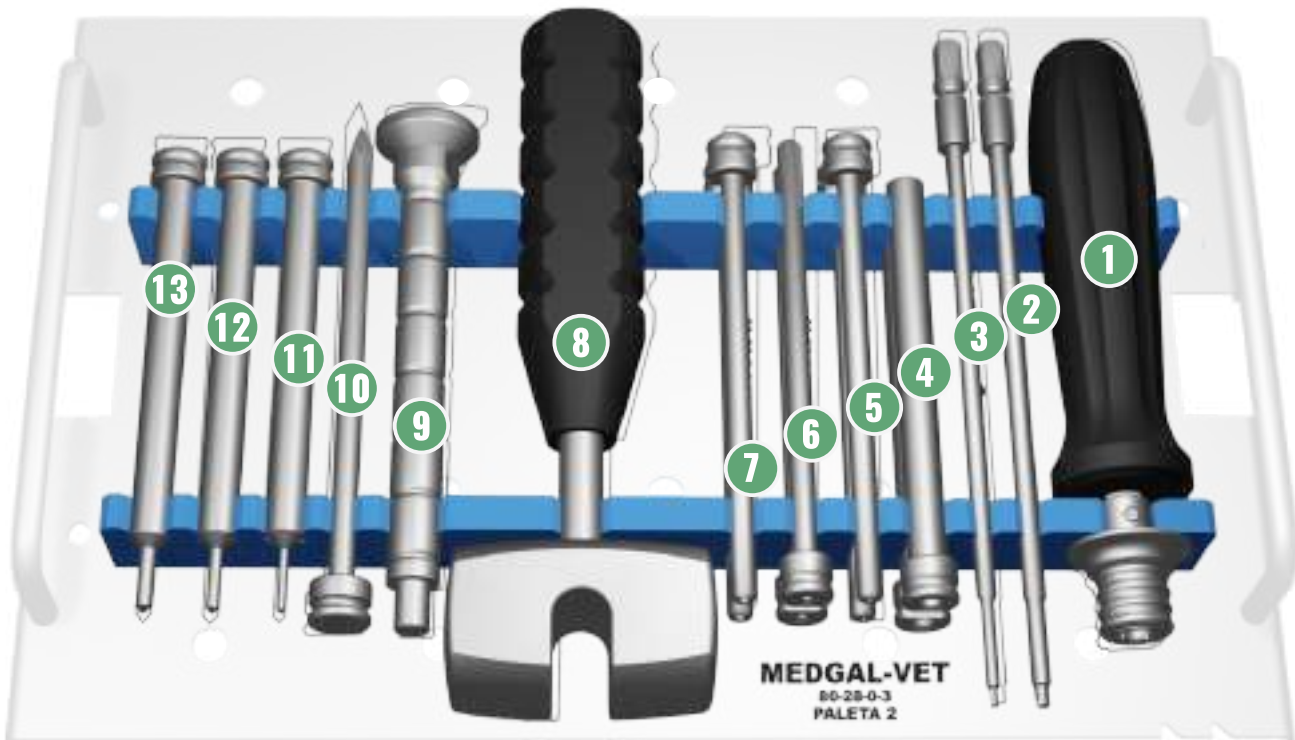

1	Handle for variable shafts	80-28-5-1
2	Torx shaft T8	80-4-43-45-16
3	Torx shaft T15	80-4-43-45-22
4	Torx shaft T6	80-4-43-45-13
5	Protection sleeve	80-28-8-2.60
6	Drill sleeve ø1.5	80-28-8-1.15
7	Drill sleeve ø1.8	80-28-8-1.18
8	Drill sleeve ø2.5	80-28-8-1.25
9	Hammer	80-28-4-1
10	Impactor	80-28-4-2
11	Trocar	80-28-2-1.60
12	Control pin ø2	80-28-1-1.20
13	Control pin ø2.7	80-28-1-1.27
14	Control pin ø3.5	80-28-1-1.35

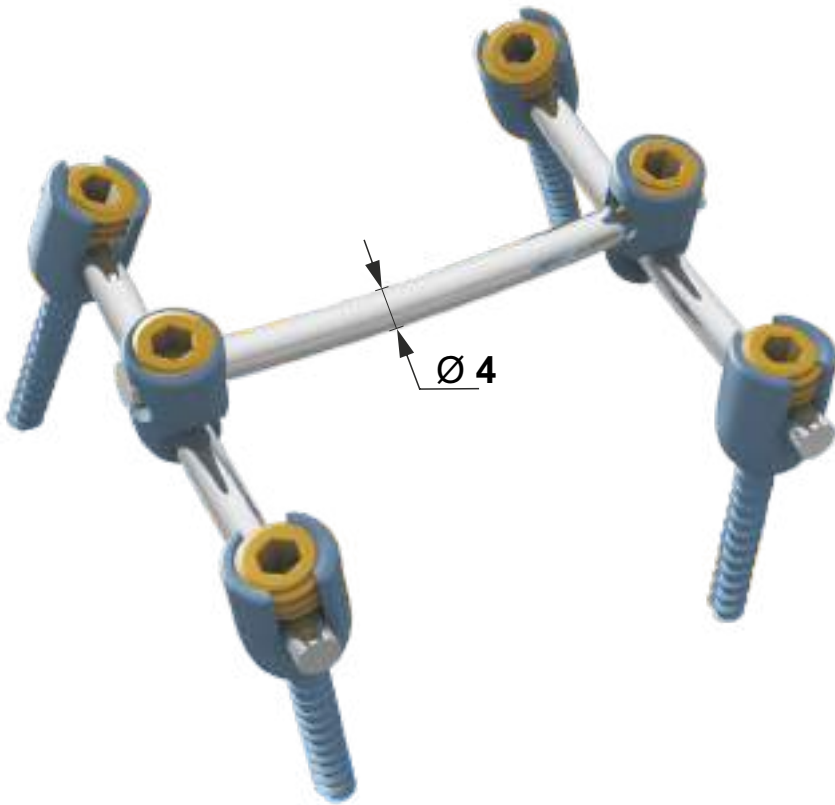

TRANSPEDICULAR SCREW

L (mm)	Ø = 4 mm
10	80-1-12-01-10
15	80-1-12-01-15
20	80-1-12-01-20
25	80-1-12-01-25
30	80-1-12-01-30
35	80-1-12-01-35
40	80-1-12-01-40
50	80-1-12-01-50

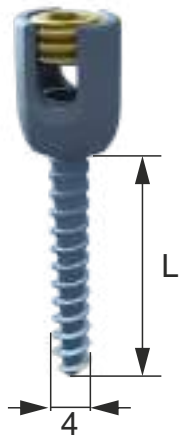

CONNECTOR

80-1-12-09-00



ROD

80-1-12-07-XX

L (mm)	Ø = 4 mm
35-100 (step 5mm)	80-1-12-07-XX
120	80-1-12-07-120
140	80-1-12-07-140
150	80-1-12-07-150
160	80-1-12-07-160
200	80-1-12-07-200

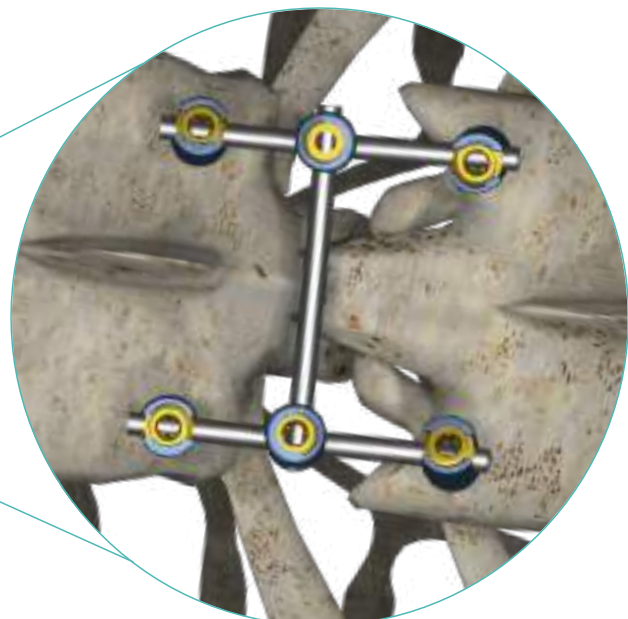
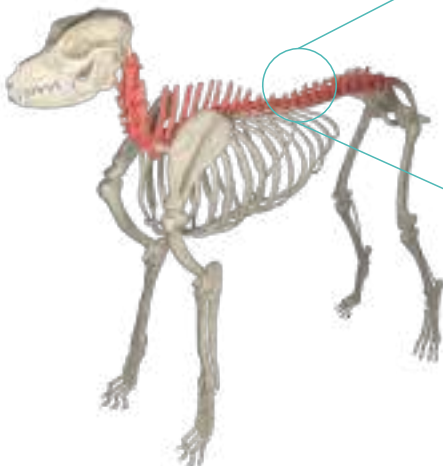

SPINE STABILIZATION INSTRUMENTS SET

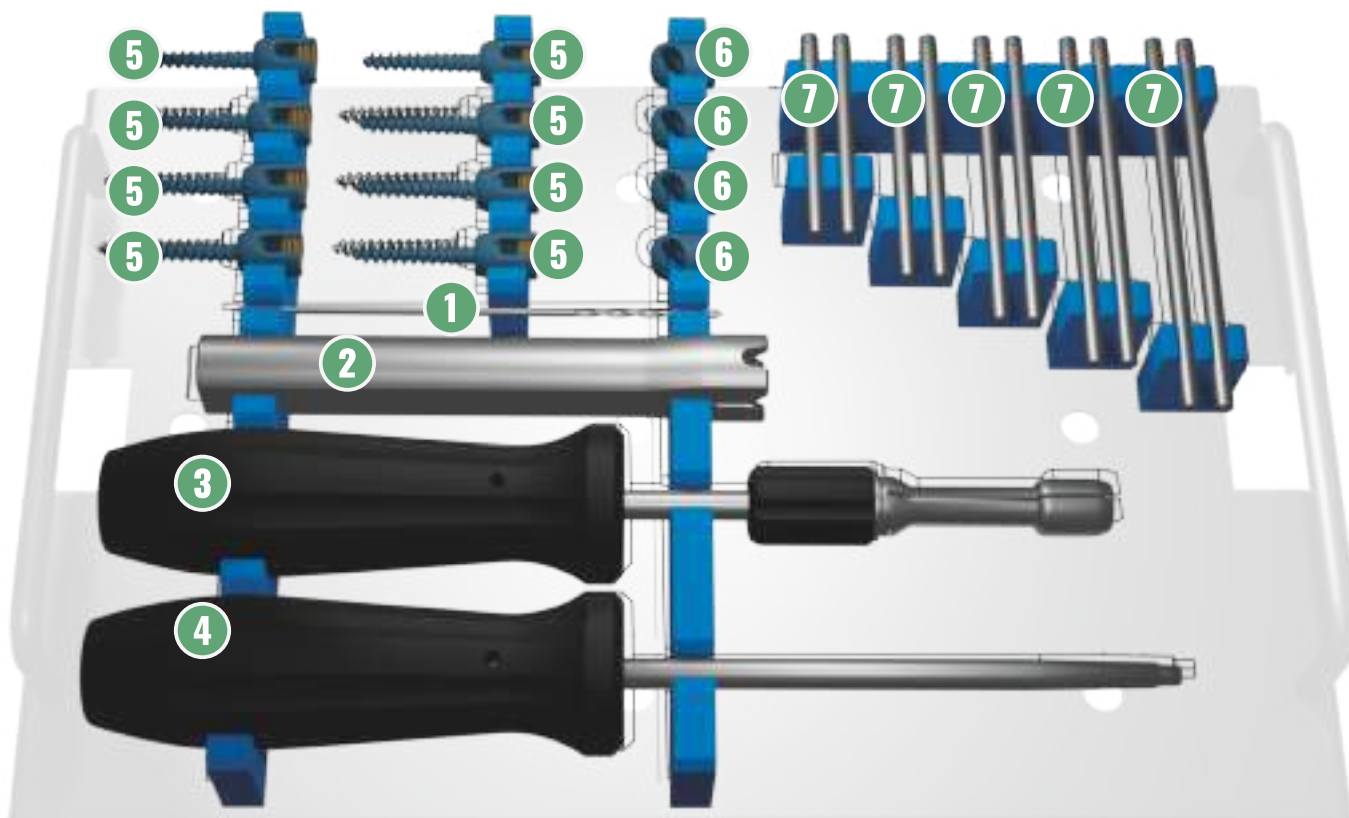

1	Drill Ø 1,5; 100mm	80-4-40-02-15
2	Pressure handle	80-28-3-2
3	Screwdriver 2,5 with hexagonal cover	80-28-5-4
4	Conical control pin 3,5	80-28-5-5
5	Transpedicular screw	80-1-12-01-xx
6	Connecting rod	80-1-12-09-00
7	Beam	80-1-12-07-xx

STRAIGHT CARBON ROD

L (mm)	REF No.	L (mm)	REF No.
∅ 3,0mm		∅ 5,0mm	
100	80-7-13-11-100	100	80-7-13-12-100
125	80-7-13-11-125	125	80-7-13-12-125
150	80-7-13-11-150	150	80-7-13-12-150
175	80-7-13-11-175	175	80-7-13-12-175
200	80-7-13-11-200	200	80-7-13-12-200
225	80-7-13-11-225	225 </td <td>80-7-13-12-225</td>	80-7-13-12-225
250	80-7-13-11-250	250	80-7-13-12-250
275	80-7-13-11-275	275	80-7-13-12-275
300	80-7-13-11-300	300	80-7-13-12-300

EXTERNAL FIXATOR

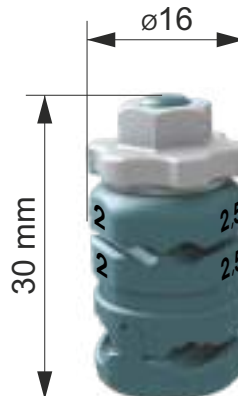

FIXATOR CLAMP
80-1-13-18-01

WRENCH s8.5 80-4-49-03-01
WRENCH T s8.5 80-4-49-01-16



SCHANZ SCREW

∅ (mm)	L (mm)	REF No.
2,0	100	80-4-06-165-10
2,5	120	80-4-06-52-12
3,0	140	80-4-06-53-14

EXTERNAL FIXATOR



SCHANZ SCREW

∅ (mm)	L (mm)	REF No.
2,0	100	80-4-06-165-10
2,5	120	80-4-06-52-12
3,0	140	80-4-06-53-14
3,5	140	80-4-06-164-14
4,0	150	80-4-06-47-15

WRENCH 10 80-4-46-01-50

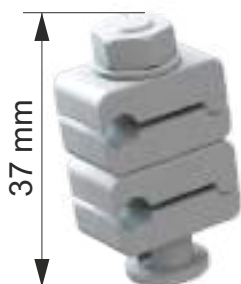

DOUBLE FIXATOR CLAMP
80-1-13-19-00.1



SINGLE FIXATOR CLAMP
80-1-13-19-00

STRAIGHT CARBON ROD

L (mm)	REF No.
∅ 5,0mm	
100	80-7-13-12-100
125	80-7-13-12-125
150	80-7-13-12-150
175	80-7-13-12-175
200	80-7-13-12-200
225	80-7-13-12-225
250	80-7-13-12-250
275	80-7-13-12-275
300	80-7-13-12-300

TTA: CAGES AND PLATES



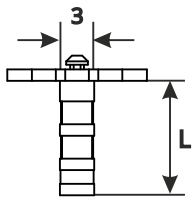

Cage 3xL

L (mm)	REF No.
10	80-1-25-13-10
13	80-1-25-13-13
16	80-1-25-13-16
19	80-1-25-13-19

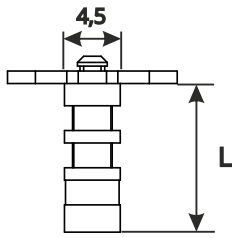

Cage 4,5xL

L (mm)	REF No.
12	80-1-25-29-12
15	80-1-25-29-15
18	80-1-25-29-18

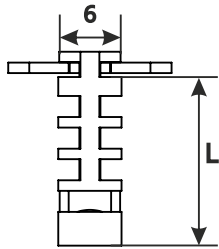

Cage 6xL

L (mm)	REF No.
16	80-1-25-14-16
19	80-1-25-14-19
22	80-1-25-14-22

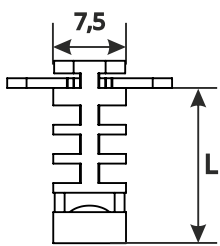

Cage 7,5xL

L (mm)	REF No.
16	80-1-25-15-16
19	80-1-25-15-19
22	80-1-25-15-22

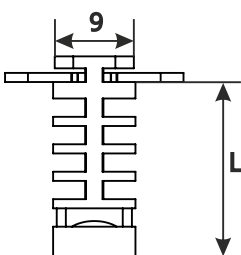

Cage 9xL

L (mm)	REF No.
19	80-1-25-16-19
22	80-1-25-16-22
25	80-1-25-16-25

CORTICAL SCREW - self-tapping with reduced head Ø 2,4



L (mm) REF
10-50 | step 2mm 80-1-01-341-L

CORTICAL SCREW - self-tapping Ø 2,4



L (mm) REF
8-60 | step 2mm 80-1-01-239-L

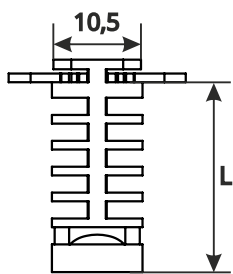

Cage 10,5xL

L (mm)	REF No.
19	80-1-25-17-19
22	80-1-25-17-22
25	80-1-25-17-25

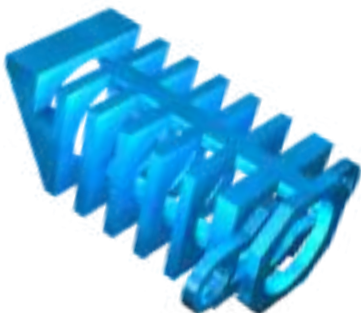
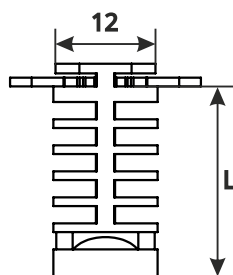

Cage 12xL

L (mm)	REF No.
22	80-1-25-18-22
25	80-1-25-18-25
28	80-1-25-18-28

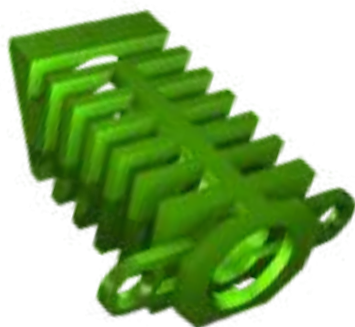
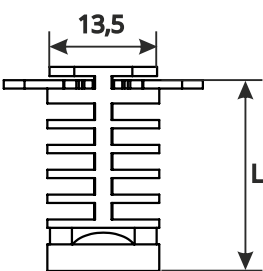

Cage 13,5xL

L (mm)	REF No.
22	80-1-25-28-22
25	80-1-25-28-25
28	80-1-25-28-28

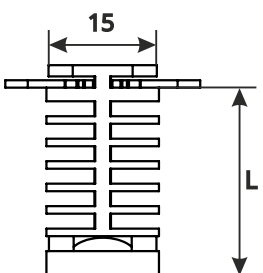

Cage 15xL

L (mm)	REF No.
25	80-1-25-19-25
28	80-1-25-19-28
31	80-1-25-19-31

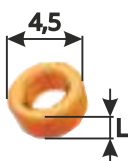

Spacer 4,5xL

L (mm)	REF No.
2	80-1-25-208-02
4	80-1-25-208-04
6	80-1-25-208-06

CORTICAL SCREW - self-tapping with reduced head Ø 2,4



L (mm) REF
10-50 | step 2mm 80-1-01-341-L

CORTICAL SCREW - self-tapping Ø 2,4



L (mm) REF
8-60 | step 2mm 80-1-01-239-L

<p>TTA nr 2</p>	80-1-25-01-002
<p>TTA nr 3</p>	80-1-25-01-003
<p>TTA nr 4</p>	80-1-25-01-004
<p>TTA nr 5</p>	80-1-25-01-005
<p>TTA nr 6</p>	80-1-25-01-006
<p>TTA nr 7</p>	80-1-25-01-007
<p>TTA nr 8</p>	80-1-25-01-008



CORTICAL SCREW - self-tapping Ø 2,7

L (mm) REF
8-60 | step 2mm 80-1-01-48-L

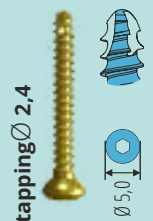

CORTICAL SCREW - self-tapping Ø 2,4

L (mm) REF
8-60 | step 2mm 80-1-01-239-L

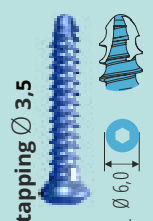

CORTICAL SCREW - self-tapping Ø 3,5

L (mm) REF
10-70 | step 2mm 80-1-01-51-L
70-90 | step 5mm

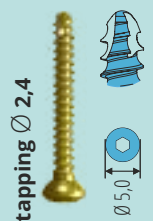

CORTICAL SCREW - self-tapping Ø 2,4

L (mm) REF
8-60 | step 2mm 80-1-01-239-L

SCREWS AND WIRES

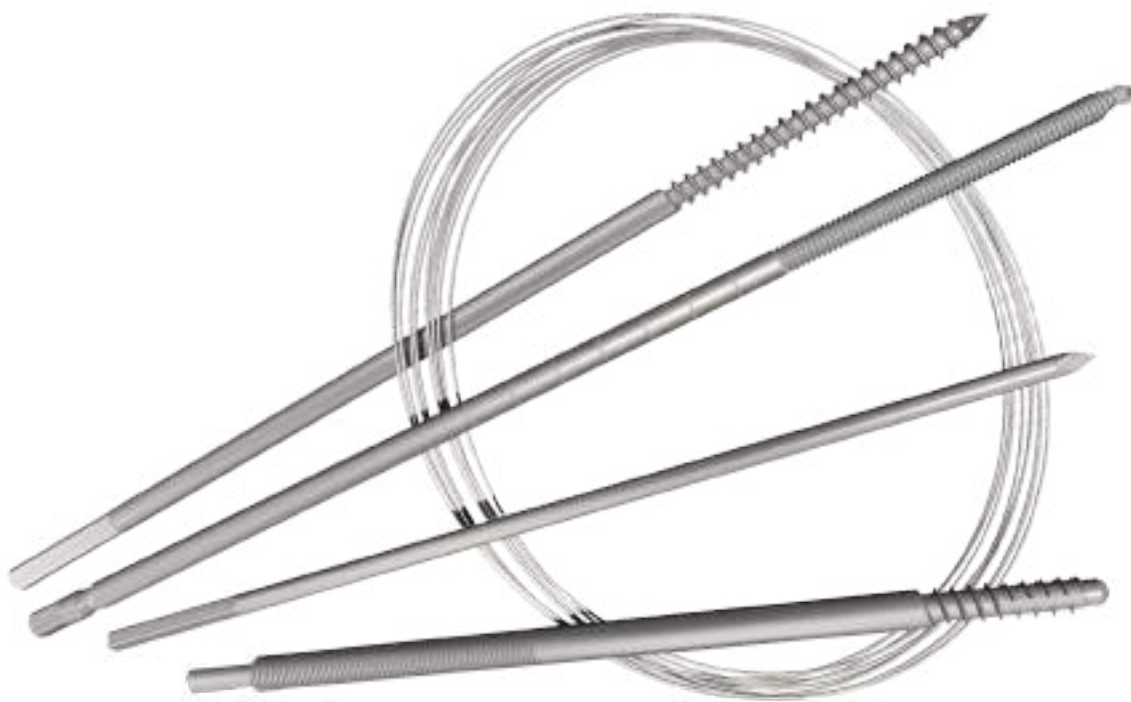

WIRE FOR CERCLAGE L=5 m



ø (mm)	REF
0,2	80-4-06-90-02
0,4	80-4-06-90-04
0,6	80-4-06-90-06
0,8	80-4-06-90-08
1,0	80-4-06-90-10
1,2	80-4-06-90-12
1,5	80-4-06-90-15
2,0	80-4-06-90-20

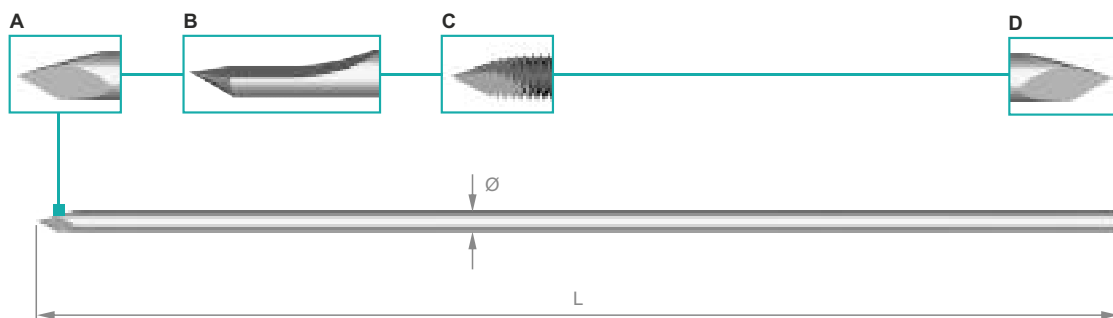

KIRSCHNER WIRE

ø (mm)	L (mm)	Blade A	Blade B	Blade C	Blade A/D
0,8	310	80-4-06-01-31	80-4-06-01-31/01	-	80-4-06-01-31/04
1,0	310	80-4-06-02-31	80-4-06-02-31/01	80-4-06-02-31/02	80-4-06-02-31/04
1,2	310	80-4-06-03-31	80-4-06-03-31/01	80-4-06-03-31/02	80-4-06-03-31/04
1,4	310	80-4-06-04-31	80-4-06-04-31/01	80-4-06-04-31/02	80-4-06-04-31/04
1,6	310	80-4-06-05-31	80-4-06-05-31/01	80-4-06-05-31/02	80-4-06-05-31/04
1,8	310	80-4-06-07-31	80-4-06-07-31/01	80-4-06-07-31/02	80-4-06-07-31/04
2,0	310	80-4-06-08-31	80-4-06-08-31/01	80-4-06-08-31/02	80-4-06-08-31/04
2,2	310	80-4-06-09-31	80-4-06-09-31/01	80-4-06-09-31/02	80-4-06-09-31/04
2,5	310	80-4-06-10-31	80-4-06-10-31/01	80-4-06-10-31/02	80-4-06-10-31/04
3,0	310	80-4-06-11-31	80-4-06-11-31/01	80-4-06-11-31/02	80-X-06-11-31/04

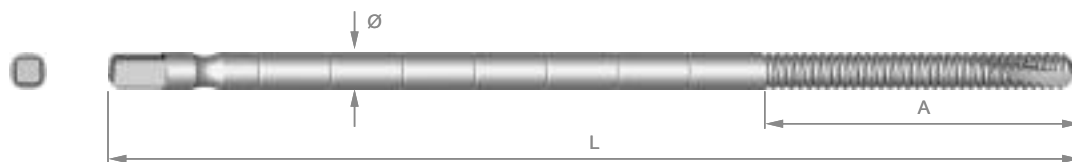

APEX SCREW

ø (mm)	L (mm)	REF No.
2,0	100	80-4-06-167-10
2,5	120	80-4-06-168-12
3,0	140	80-4-06-59-36
3,5	140	80-4-06-169-14
4,0	150	80-4-06-59-46
4,5	160	80-4-06-170-16

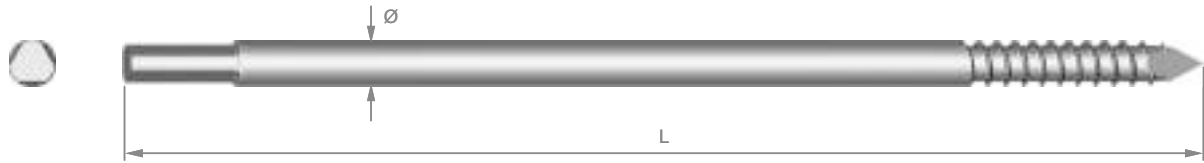

SCHANZ SCREW

ø (mm)	L (mm)	REF No.
2,0	100	80-4-06-165-10
2,5	120	80-4-06-52-12
3,0	140	80-4-06-53-14
3,5	140	80-4-06-166-14
4,0	160	80-4-06-54-16
4,5	160	80-4-06-55-16

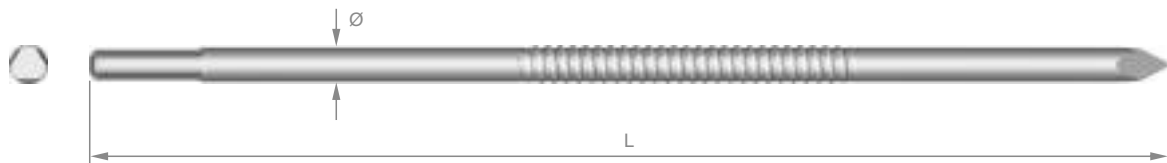

STEINMANN SCREW

ø (mm)	L (mm)	REF No.
2,0	120	80-4-06-162-12
2,5	120	80-4-06-163-12
3,0	140	80-4-06-50-14
3,5	140	80-4-06-164-14
4,0	150	80-4-06-46-15
4,5	150	80-4-06-47-15

SCREW SELECTION TABLE BY PATIENT'S WEIGHT (kg)

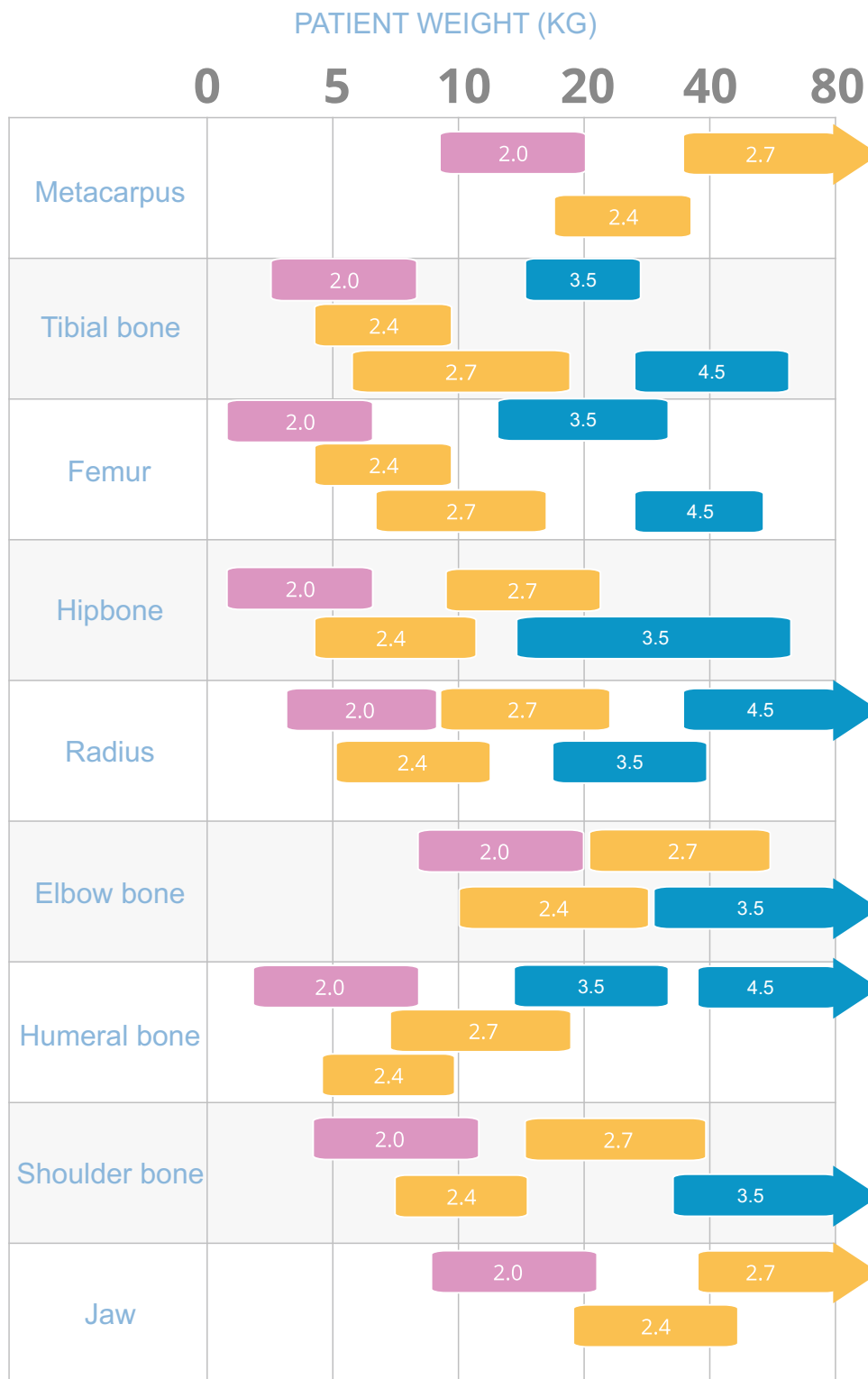



OVER
35 YEARS
EXPERIENCE

WWW.MEDGALVET.COM.PL



SINCE
1982



MEDGAL Sp. z o.o.
16-001 Księżyno
ul. Niewodnicka 26A





MEDGAL Sp. z o.o.
ul. Niewodnicka 26A
16-001 Księżyno



www.medgalvet.com.pl



kontakt@medgalvet.com.pl



85 663 23 44